

INSTALLATION PROCEDURE

LINEA TOUCH LED HANDRAIL



spm-international.com



WALL PROTECTIONS
& HANDRAILS

Sp^m
wall protection

CONTENTS







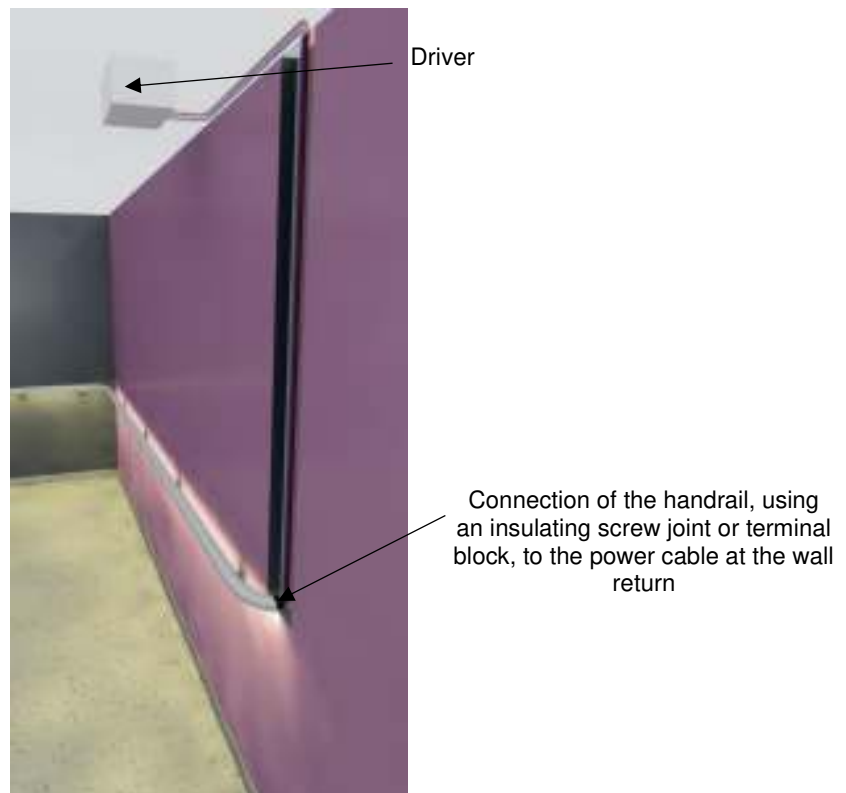
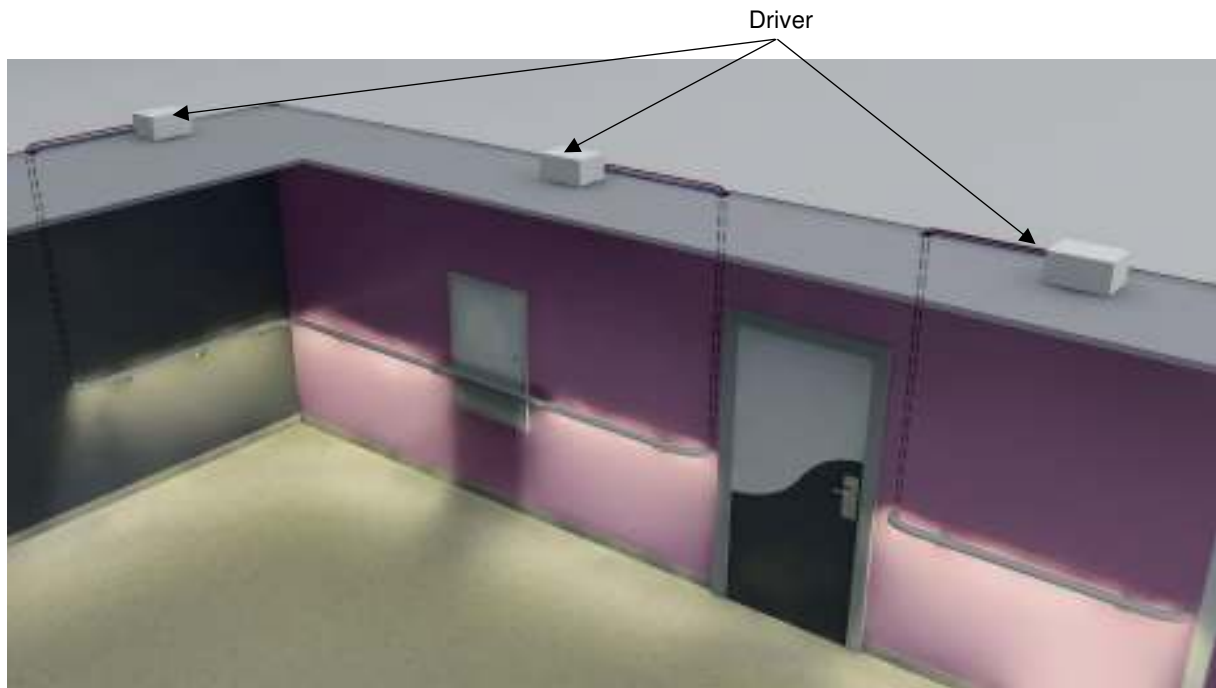

CONTENTS	2
BEFORE YOU BEGIN	3
1. COMPOSITION OF THE LINEA'TOUCH LED SYSTEM	4
2. TOOLS REQUIRED	5
3. TYPES OF WALL/INSTALLATION TECHNIQUES	5
4. LED SYSTEM INFORMATION	6
5. PREPARATION AND CUTTING TECHNIQUES	7
■ 5.1 - MEASURING THE ALUMINIUM AND PVC PROFILE LENGTHS.....	7
■ 5.2- CUTTING THE ALUMINIUM AND PVC LENGTHS AND CUTTING THE MADE-TO-MEASURE ACCESSORIES	8
6. ASSEMBLING THE HANDRAIL	8
■ 6.1- INSTALLATION ON A STRAIGHT WALL.....	8
■ 6.2- INSTALLATION WITH ANGLE PIECES.....	12
■ 6.3- PROFILE-TO-PROFILE ASSEMBLY	17
7. FIXING THE HANDRAIL TO THE WALL	18
■ 7.1- DRILLING HEIGHT.....	18
■ 7.2- CONNECTING TO THE POWER SUPPLY	19
■ 7.3- FIXING.....	19
8. SERVICE DUCT	20
9. MAINTENANCE	21

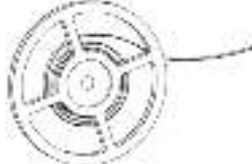
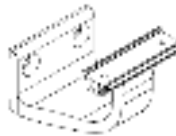
BEFORE YOU BEGIN



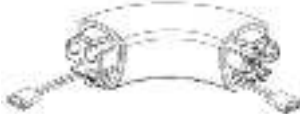



- Before you install the LINEA'TOUCH LED handrail, the driver must be installed by an electrician (SPM 24 VDC 60 W constant voltage SELV unit or other unit sufficiently powerful for a 9.6 W/m LED band).
- The handrail must be connected, using an insulating screw joint or terminal block (not supplied), to a **24 V** cable (not supplied) coming out of the wall. Check first that the system is disconnected from the power supply.
- All electrical work must be carried out by an electrician.



1. COMPOSITION OF THE LINEA'TOUCH LED SYSTEM

	<p>Linea'Touch LED Trilobed handrail with closer on continuous aluminium profile L. 4.00 m Ref. PVC sheathed: MEGLDPVC Decowood: MEPLDBOI Anodised: MEALDSAA</p>		<p>LED band 5 m reel Ref. LD000BLC+B</p>
	<p>Linea'Touch LED 55 mm quick-removable bugled bracket in silver anodised effect aluminium Ref. MELD0ANO+S5</p>		<p>Wire connector Ref. LD000SCO+COF</p>
	<p>Antibacterial PVC wall return with bactericidal joint (left or right - to be specified) Ref. MEGLDPVC+ER or MEALDANO+ER</p>		<p>Coloured filter L. 1,000 mm Ref. LD000PVC+FI</p>
	<p>Linea'Touch LED antibacterial PVC 90° internal/external angle kit with bactericidal joints and integrated wire cable for fitting round corners Ref. MEGLDPVC+A or MEALDANO+A</p>		<p>LINEA'Touch LED joining block with bactericidal joint Ref. MELD0NOR+J</p>
	<p>Linea'Touch LED antibacterial PVC 90° to 135° made-to- measure internal/external angle kit with bactericidal joints and integrated wire cable Ref. MEGLDPVC+ASM or MEALDANO+ASM</p>		<p>24 V 60 W Driver (maximum handrail length 8 m) Ref. LD000SCO+DR</p>

2. TOOLS REQUIRED

	Circular saw with carbide blade for aluminium and PVC		2.5 mm and 2 mm diameter Allen keys
	Measuring tape and pencil		Electrical insulating tape
	Drill and screwdriver		Screws and expansion plugs

3. TYPES OF WALL/INSTALLATION TECHNIQUES

- The table below shows the installation techniques to be used for the main wall surfaces found in the building industry.

TYPE OF WALL	INSTALLATION PROCEDURE
❖ Walls with wooden studs	Woodscrews, 6 x 50 mm
❖ Metallic structures	Self-tapping screws, 6 x 50 mm
❖ Plasterboard (single skin), hollow brick, hollow breeze block (*)	Metallic expansion plug, 6 x 50 mm
❖ Plasterboard (double skin)	Metallic expansion plug, 6 x 60 mm
❖ Concrete walls	FISCHER-type plugs, 8 mm diameter for 6 x 50 mm screws
❖ Solid brick and old walls	FISCHER-type plugs, 8 mm diameter for 6 x 50 mm screws
❖ Hollow plaster tiles, cellular concrete	FISCHER-type plugs, 8 mm diameter for 6 x 50 mm screws

(*) If the area is subject to heavy traffic, add an extra wood or metal stud in the partition to withstand a vertical and horizontal pressure level of 100 kg between two fixing spacers.

- If installing the handrail on a single-skin plasterboard wall (such as Gypsum), add wood or metal reinforcements according to the supplier's recommendations.
- Use countersinking screws.

4. LED SYSTEM INFORMATION



System compliant with European Directives



Class III system



Module for mounting
For replacement by an electrician only



System compliant with RoHS Directive



Offcuts and end-of-life electrical items must not be disposed of with ordinary waste, but must be sent to SPM International for recycling:

SPM international S.A.S.
Déchet D3E
16 rue Isabelle Eberhardt
CS 92083 - 31019 Toulouse Cedex 2 - FRANCE

System designed for:

- direct installation on “normally flammable surfaces”.
- indoor use only.

LED band specifications:

Voltage	24 V
Power	9.6 W/m
Luminous flux	670 lm/m
Neutral white	4000K
CRI	≥ 80
Base	LED
IP	20
Operating temperature	-25°/60°C

The driver is available as an option from SPM; it is a constant voltage SELV unit:

Output voltage Uout	24 VDC
Max. power	60 W
Maximum length	8 m

The light source contained in this lighting fixture must only be replaced by an electrician.

5. PREPARATION AND CUTTING TECHNIQUES

■ 5.1 - MEASURING THE ALUMINIUM AND PVC PROFILE LENGTHS

- Measure each section of wall in order to cut and prepare the handrail lengths before installation.
- At each end of the handrail, leave a clearance of at least 30 mm between the end of the handrail (with its wall return) and the end of the wall or door frame. This clearance will allow the wall return to be removed if it has to be replaced.

Example of measuring a straight wall section:

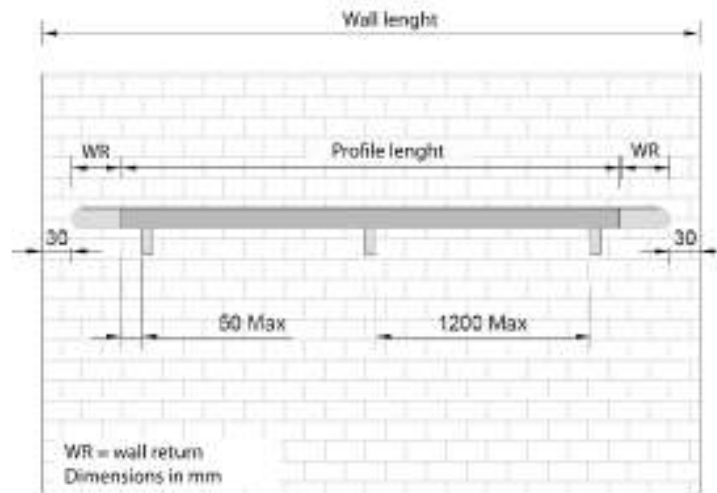

Example of measuring a wall with an internal/external angle piece:

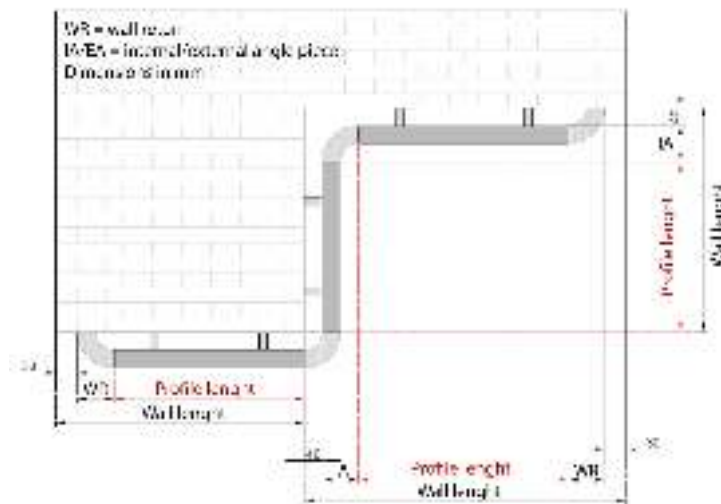

- Based on the measurement of the wall minus the necessary clearance of 30 mm at the end(s), use the following table to calculate the lengths of the aluminium and PVC profiles to be cut depending on the accessories used:

HANDRAIL	Wall return	Internal/external angle piece
LINEA'TOUCH LED Aluminium & PVC	- 82 mm	Internal: - 122 mm External: 0 mm

(The values include the dimensions of the joints)

■ 5.2- CUTTING THE ALUMINIUM AND PVC LENGTHS AND CUTTING THE MADE-TO-MEASURE ACCESSORIES

- Once the lengths of the aluminium and PVC profiles have been calculated, cut the profiles to length using a circular saw with an appropriate blade (preferably a fine-toothed blade in order to give a smooth edge). Recommended blades feature alternating flat teeth and trapezoidal teeth. Refer to "Tools Required".



- For a better finish, it is recommended that the aluminium profile and the PVC profile be snap-fixed together before push-cutting, and held from one side.



6. ASSEMBLING THE HANDRAIL

■ 6.1- INSTALLATION ON A STRAIGHT WALL



- Refer to paragraphs 5.1 and 5.2 for calculating lengths and cutting the profiles.
- Cut the necessary length of LED band. The band can be cut every 50 mm. Leave at least 35 mm without any band at each end of the profile, for the connector and wall return. The band must be cut where indicated by the symbol (✂). **Cover the end of the band with electrical insulating tape.**

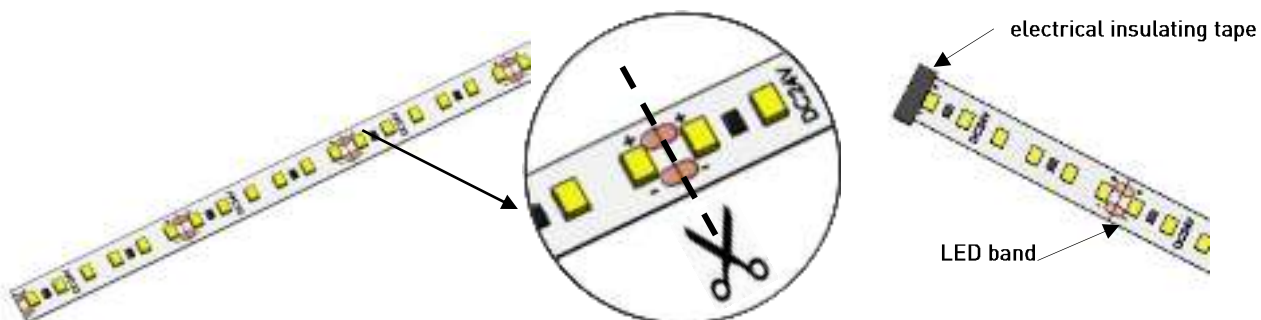

Never cut the LED band when the system is connected to the power supply.

- Connect the wire connector (driver side) to the LED band (peel the band adhesive on **1 cm** to facilitate the connection).



Comply with electrical standards: connect the red wire to the positive terminal and the black wire to the negative terminal of the LED band.

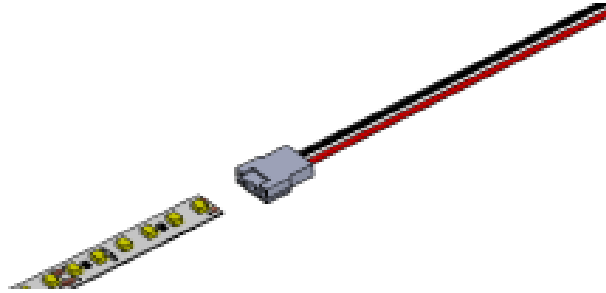

- Insert the LED band(s) (and filters) into the groove in the profile(s). The LEDs on the band must be facing the floor. The bands and filters can be secured to each other with adhesive tape to facilitate insertion. **Do not adhesivate the LED band inside the groove.**



If coloured filter is used, hide the LED band located in the connector using electrical insulating tape. The coloured filter doesn't pass over it. Moreover, coloured filters must be inserted between each bracket.

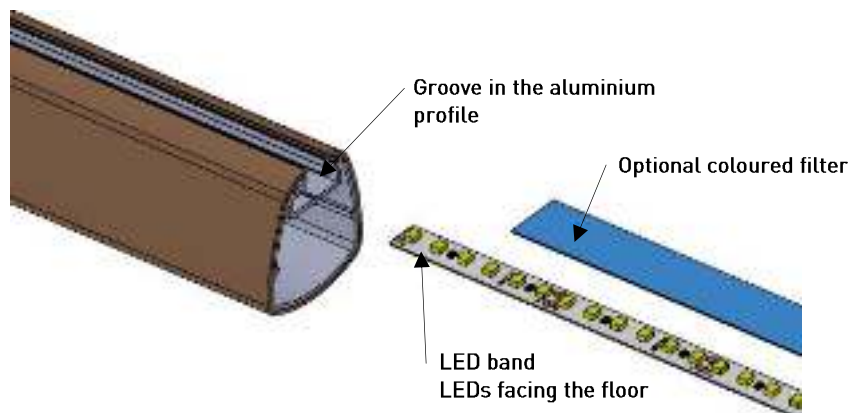

- If the profile is longer than one LED band, the tapes must be connected to each other. To do this, use the single connector and the wire connector (peel the band adhesive on **1 cm** to facilitate the connection).



Comply with electrical standards: connect the red wire to the positive terminal and the black wire to the negative terminal of the LED band.

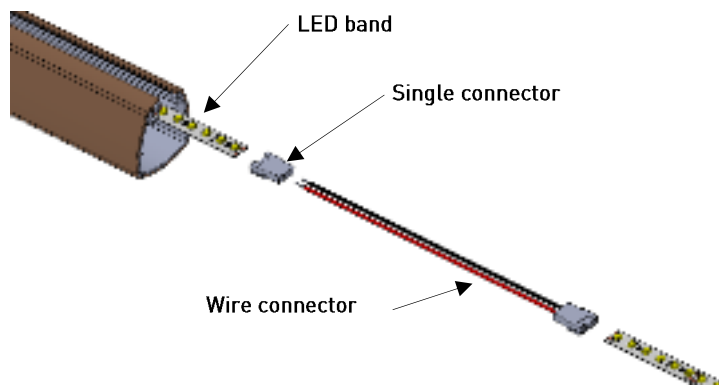

- Slide the brackets into the groove in the aluminium profile on top of the LED bands. If several brackets must be installed, space the brackets at no more than 1,200 mm intervals (use 800 mm intervals in areas of heavy use or on less robust wall surfaces such as plasterboard). To facilitate the bracket's insertion, it's possible to unscrew them slightly using a Allen Hex-key 2.

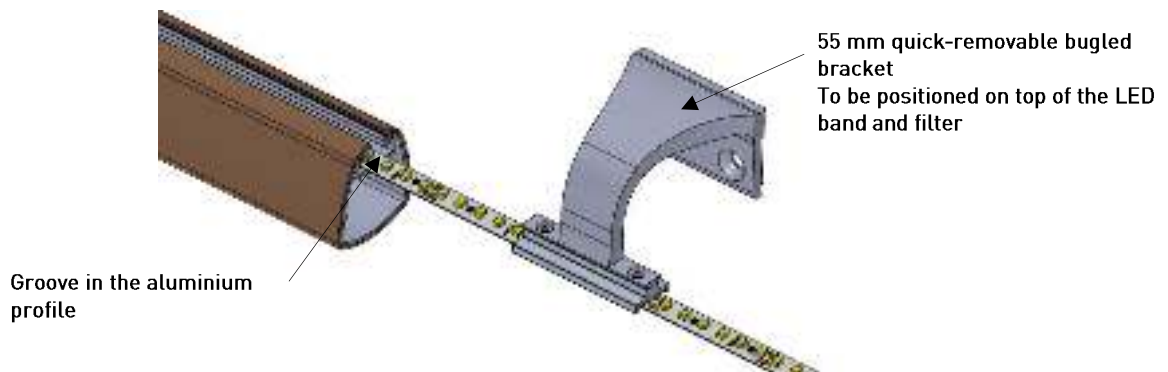

- Position the end brackets a maximum of 50 mm from the end of the profile.

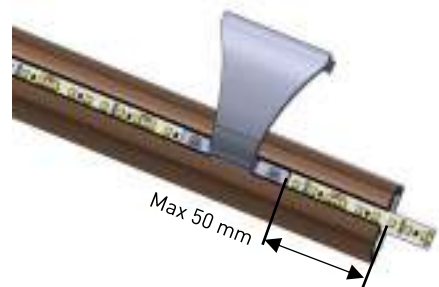

- Position the wall returns.
At the power supply end, pass the wire connector through the hole provided.

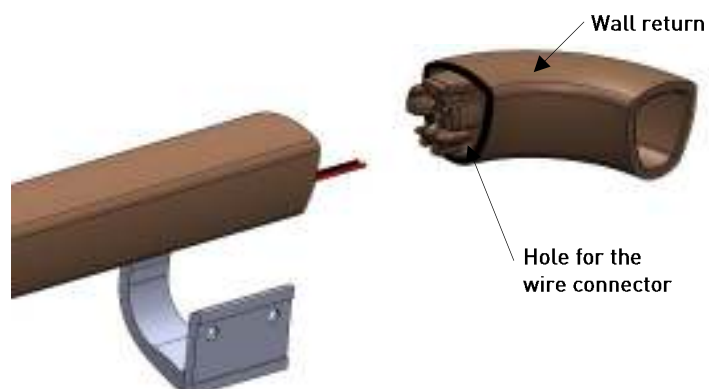

- Finally, fix the brackets and wall returns to the aluminium profile using the 2 mm and 2.5 mm Allen keys.

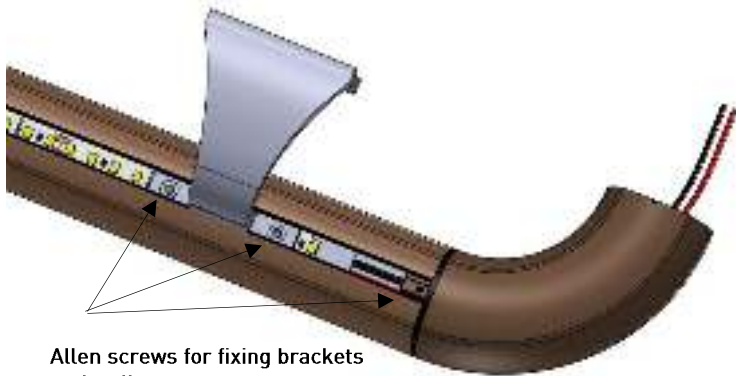

Allen screws for fixing brackets and wall returns

- Finally, cut the closer to the desired length and snap-fit it into the groove.

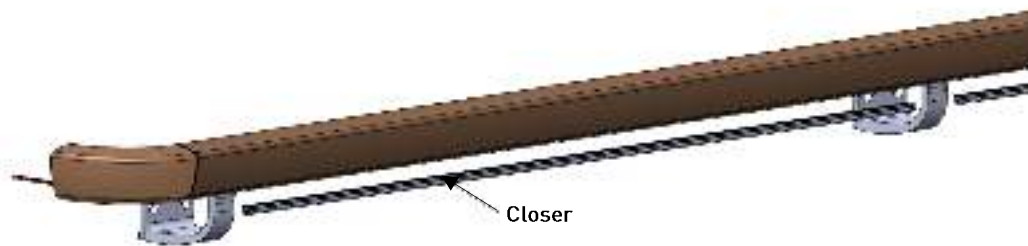

■ 6.2- INSTALLATION WITH ANGLE PIECES

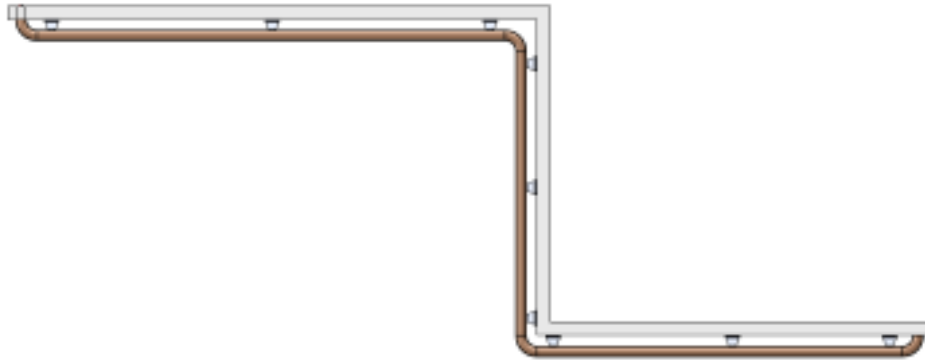

- Refer to paragraphs 5.1 and 5.2 for calculating lengths and cutting the profiles.
- Cut the necessary lengths of LED band. The band can be cut every 50 mm. Leave at least 35 mm without any band at each end of the profile, for the connectors and wall return. The band must be cut where indicated by the symbol (✂).

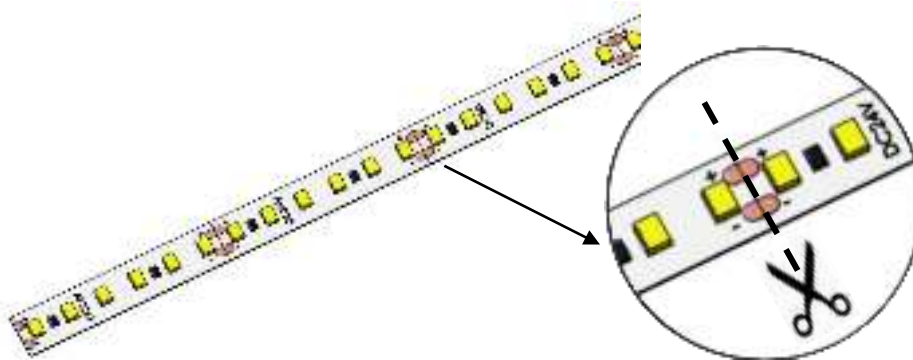

Never cut the LED band when the system is connected to the power supply.

- Connect the wire connector (driver side) to the LED band (peel the band adhesive on **1 cm** to facilitate the connection).



Comply with electrical standards: connect the red wire to the positive terminal and the black wire to the negative terminal of the LED band.

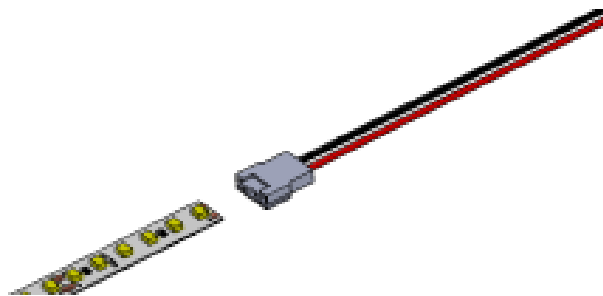

- Insert the LED band(s) (and filters) into the groove in the profile(s). The LEDs on the band must be facing the floor. The bands and filters can be secured to each other with adhesive tape to facilitate insertion. **Do not adhesivate the LED bands inside the groove.**



If coloured filter is used, hide the LED band located in the connector using electrical insulating tape. The coloured filter doesn't pass over it. Moreover, coloured filters must be inserted between each bracket.

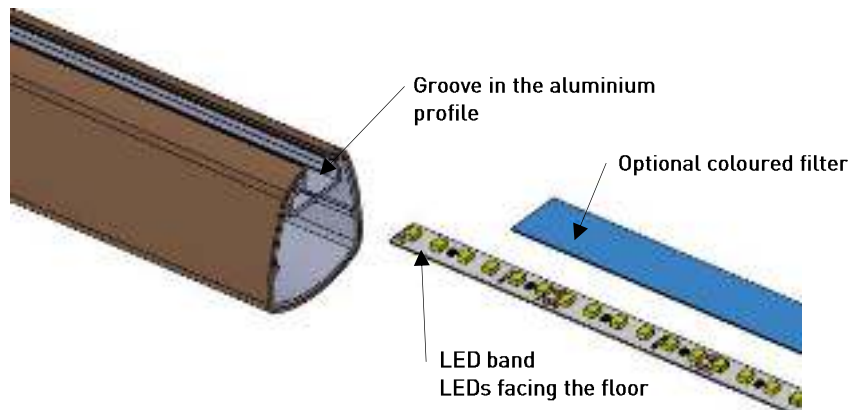

- If the profile is longer than one LED band, the bands must be connected to each other. To do this, use the single connector and the wire connector (peel the band adhesive on **1 cm** to facilitate the connection).



Comply with electrical standards: connect the red wire to the positive terminal and the black wire to the negative terminal of the LED band.

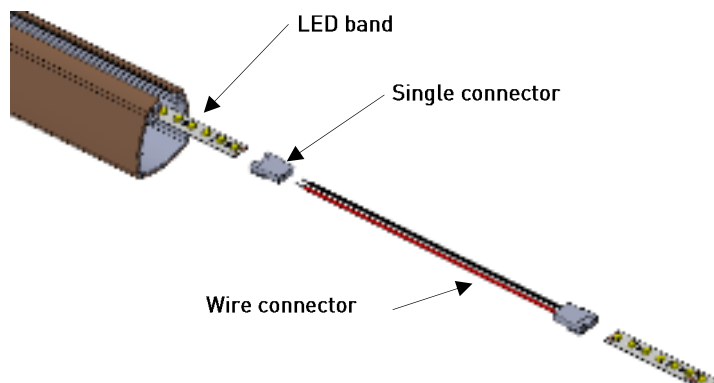

- Slide the brackets into the groove in the aluminium profile on top of the LED bands. If several brackets must be installed, space the brackets at no more than 1,200 mm intervals (use 800 mm intervals in areas of heavy use or on less robust wall surfaces such as plasterboard). To facilitate the bracket's insertion, it's possible to unscrew them slightly using a Allen Hex-key 2

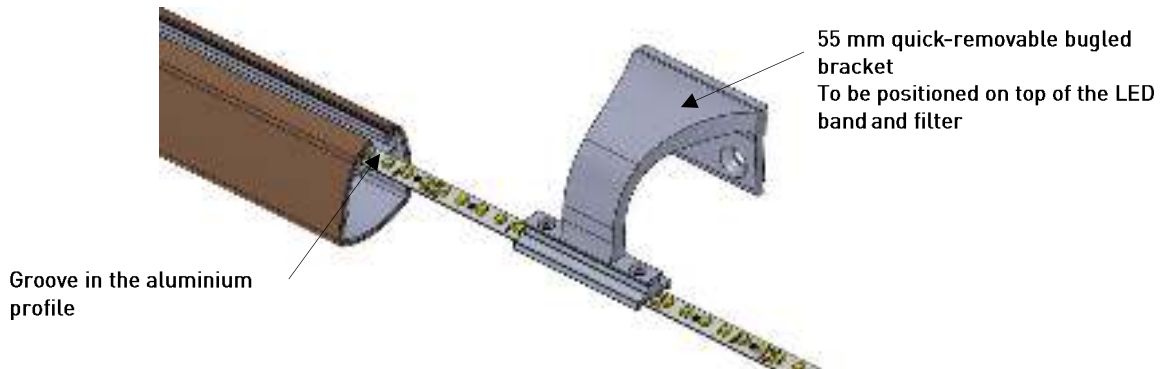

- Position the end brackets a maximum of 50 mm from the end of the profile.

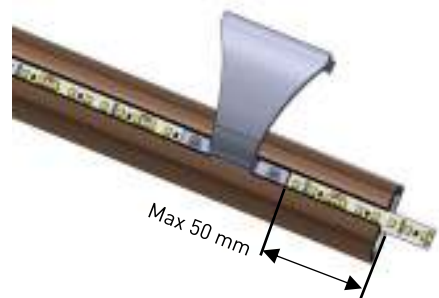

- **Angles's procedure**

- Connect the wire connector of the angle to the LED band of the 1st profil (peel the tape adhesive on 1 cm to facilitate the connection) respecting : connect the red wire to the positive terminal and the black wire to the negative terminal of the LED band.



In certain cases, when connecting, connectors having only one direction of connection, it can happen that the red wire is connected to the negative terminal and the black wire to the positive terminal of the LED band It's important in that case to remember this colour change in order to keep the polarity of the installation.

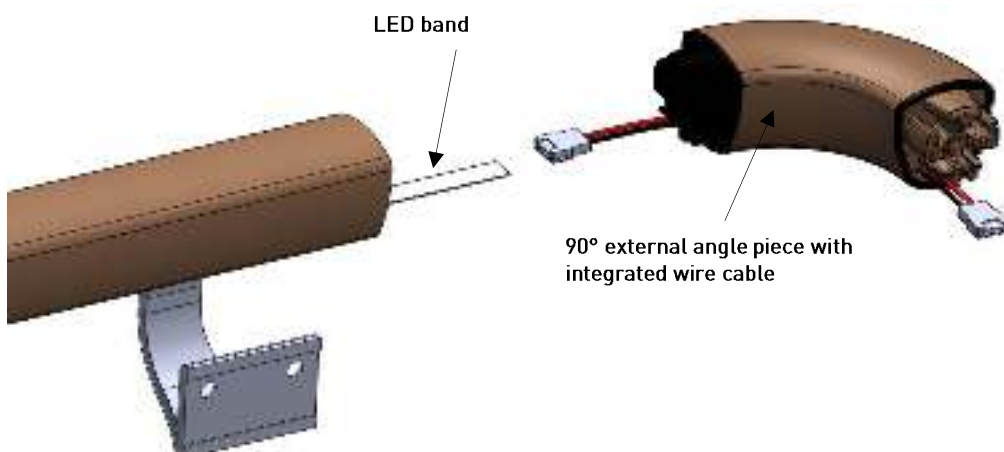

- Position et assemble the angle with the 1st profil

90° external angle piece with integrated wire cable



- Position and assemble the wall return at the power supply side (pass the wire connector through the hole provided).

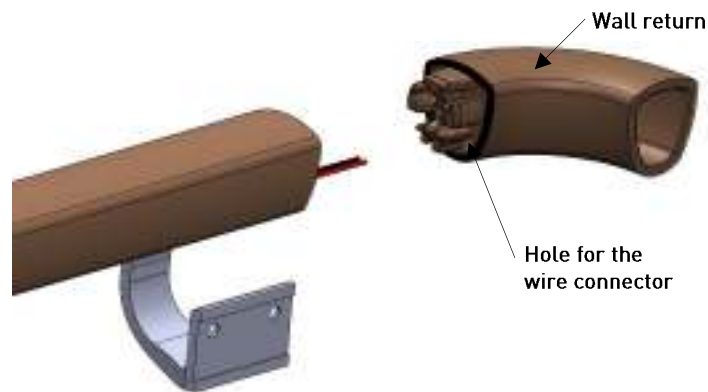

- Connect the wire connector of the angle to the LED band of the 2nd profil (peel the band adhesive on 1 cm to facilitate the connection) respecting : connect the red wire to the positive terminal and the black wire to the negative terminal of the LED band.



Sometimes, when connecting, connectors having only one direction of connection, it can happen that the red wire is connected to the negative terminal and the black wire to the positive terminal of the LED band. It's important in that case to remember this colour change in order to keep the polarity of the installation.

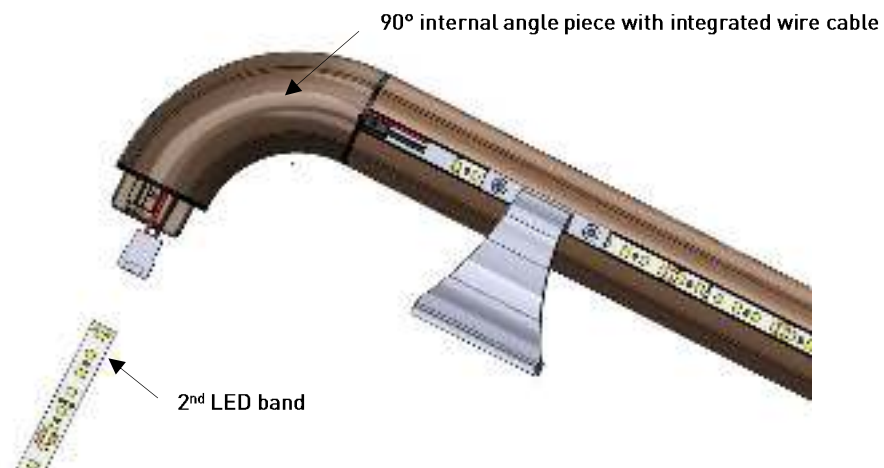

- Reminder : for any end of section ending with a wall return or an end-cap, **you must cover the end of the LED band with an electrical insulating tape.**

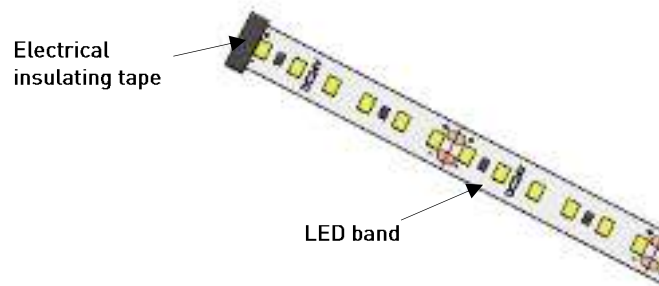

- Insert the LED band, the brackets and coloured filters (option) into the 2nd profil following the same procedure as seen before.
- Position and assemble the angle and the wall return with the 2nd profil.

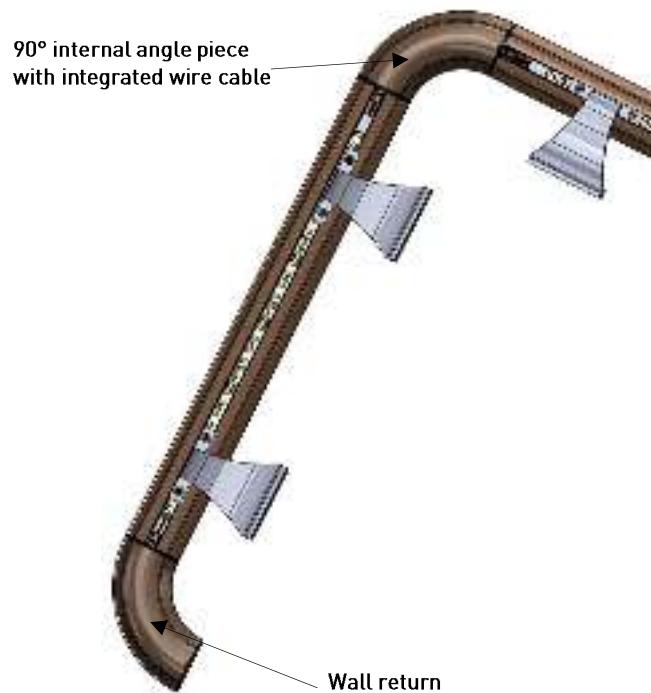

- Finally, fix the brackets and wall returns to the aluminium profile using the 2 mm and 2.5 mm Allen keys.

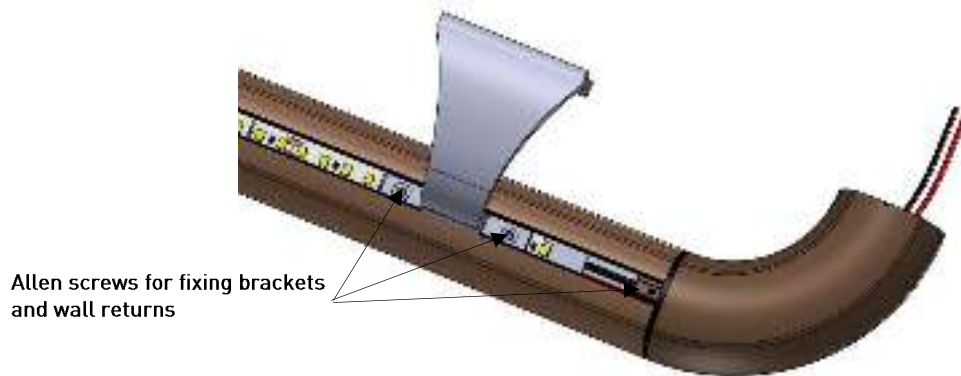

- Finally, cut the closer to the desired length and snap-fit it into the groove.

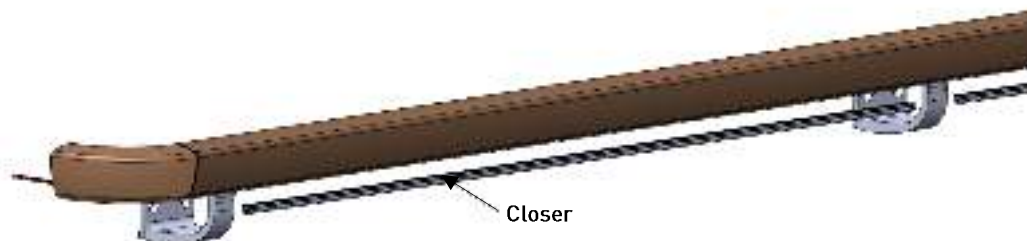

■ 6.3- PROFILE-TO-PROFILE ASSEMBLY

- Insert the wire connector into the hole in the joining block and connect the single connector to the wires. Connect the connectors to the LED bands (peel the band adhesive on 1 cm to facilitate the connection).



Comply with electrical standards: connect the red wire to the positive terminal and the black wire to the negative terminal of the LED band.

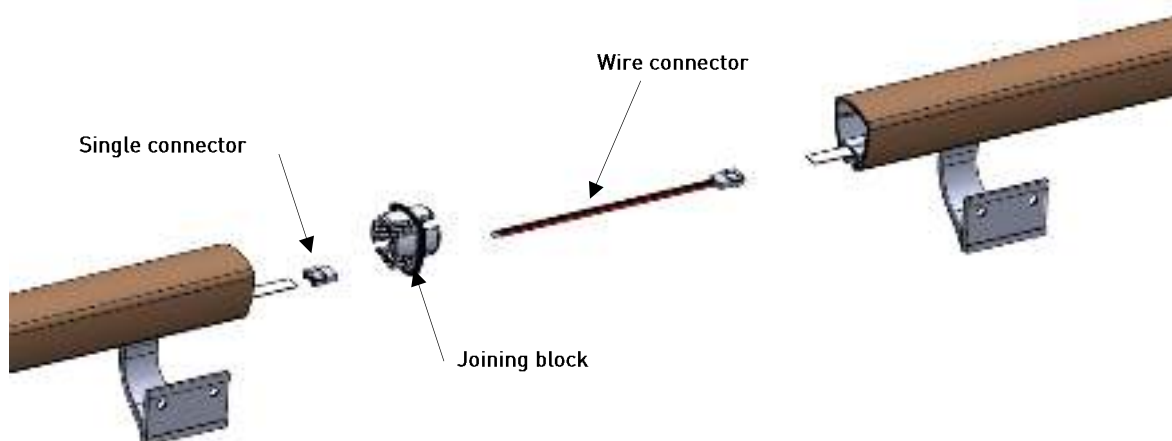

- Position the brackets a maximum of 50 mm from the ends of the profiles.

- Fix the joining block and brackets to the aluminium profile using the 2 mm and 2.5 mm Allen keys.

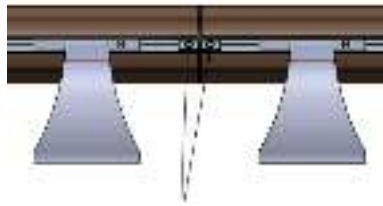

2.5 mm Allen fastening screw

7. FIXING THE HANDRAIL TO THE WALL

■ 7.1- DRILLING HEIGHT

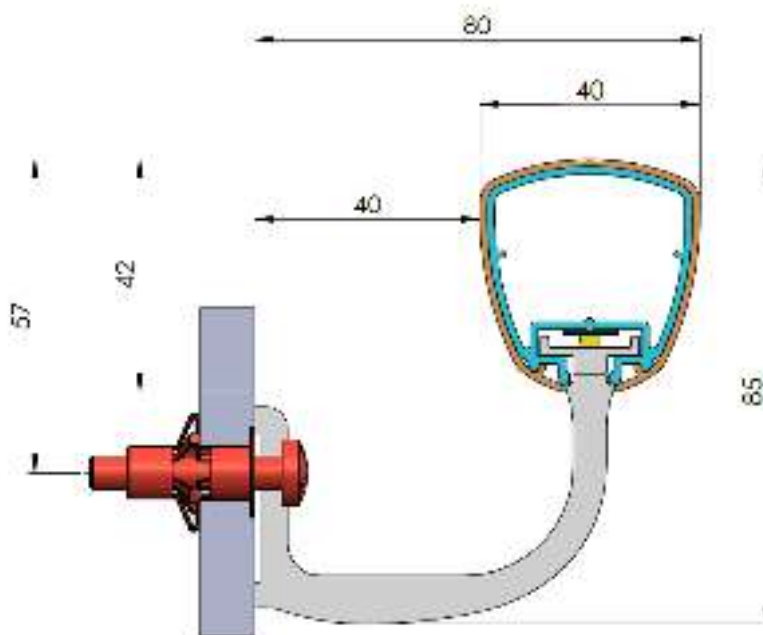

For a handrail height of 900 mm (measured at the handrail's upper surface), the drilling height is 843 mm (900 - 57).

■ 7.2- CONNECTING TO THE POWER SUPPLY



- Check that the power supply is disconnected.
- Connect the wire connector (**red and black wires**) to the cable from the driver with an insulating screw joint or terminal block.
- Installation requires the assistance of an electrician.

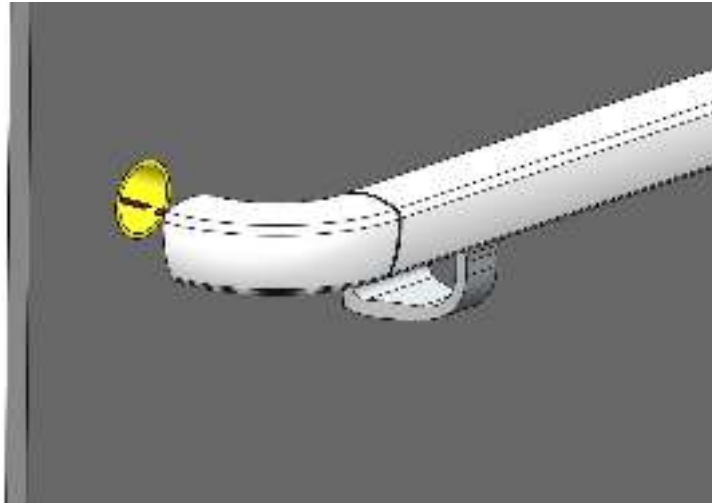

■ 7.3- FIXING

- Place the handrail against the wall. Allow a clearance of at least 30 mm between the end of the wall and the end of the handrail. This clearance will allow the wall returns to be replaced if necessary without disassembling the entire handrail.

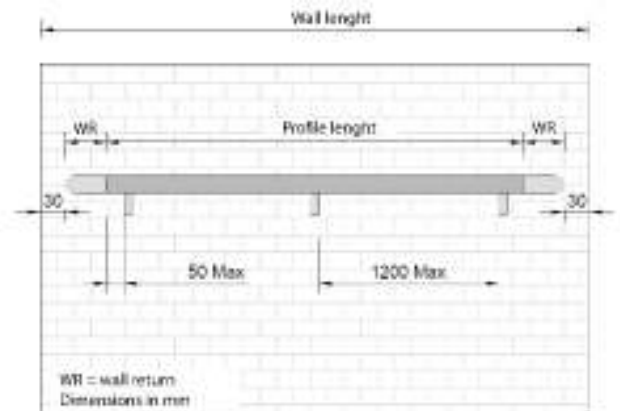

- Mark the holes to be drilled for the brackets.
- Drill the holes marked on the wall. Insert the expansion plugs.
- Fix the brackets to the wall, starting with the ends.

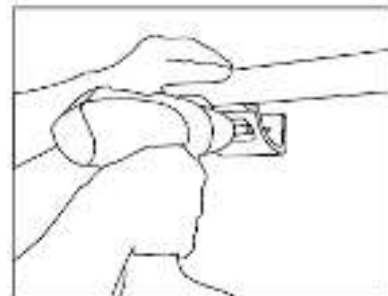

8. SERVICE DUCT

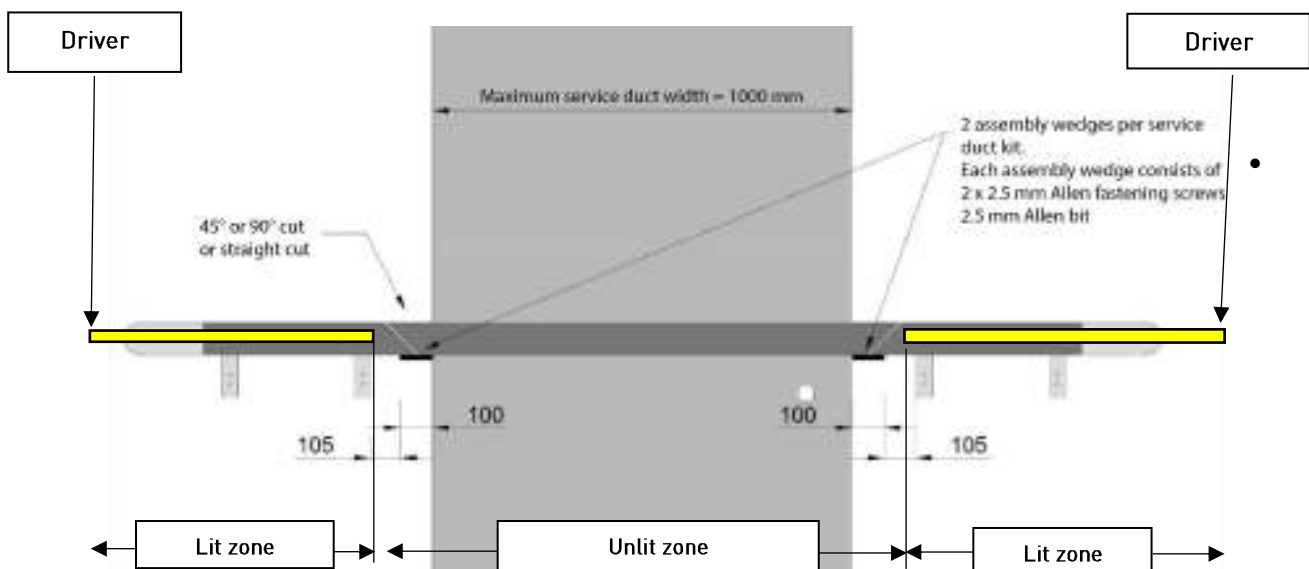
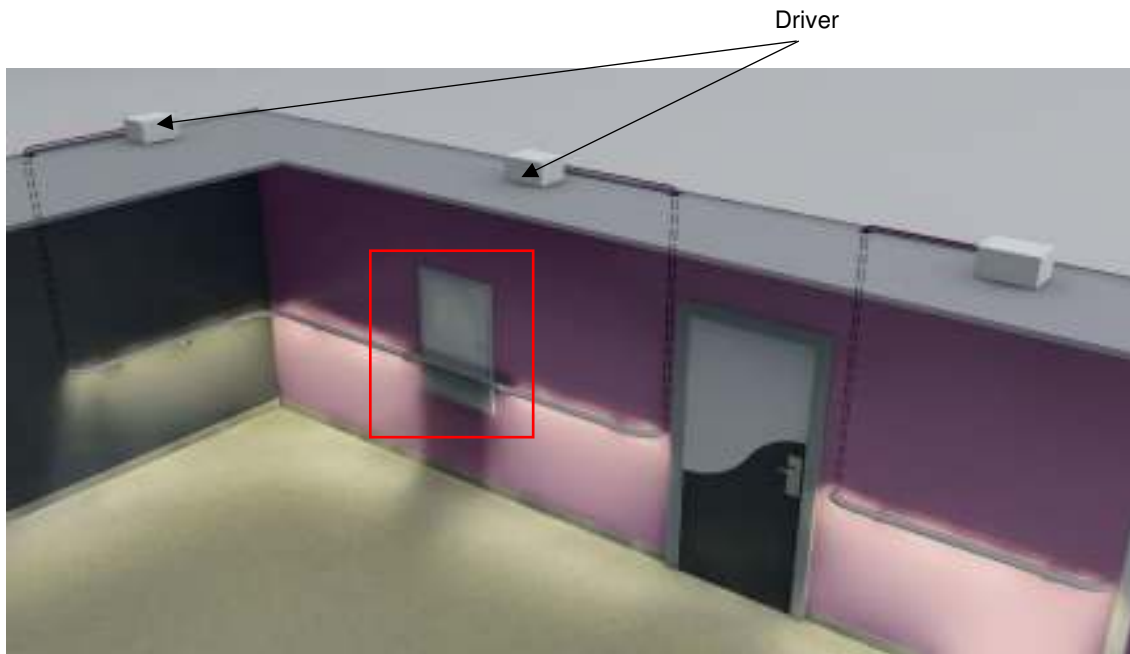

- The service duct kit is made on-site by cutting a section of handrail as long as the width of the service duct plus 100 mm (100 mm equals 2 x half the length of an assembly wedge). The cut may be at 45° or 90°. Next, position the elements in accordance with the dimensions shown on the drawing above.
- Be sure to trim the handrail's closer appropriately in order to allow the assembly wedges to slide.
- **The removable part of the handrail does not contain any LED band; allowance must be made for an unlit zone of the profile length.**

9. MAINTENANCE

- Procedure for changing a LED band:



*Module for mounting
For replacement by an electrician only*

- Disconnect the power supply,
- Remove the closer from the wall return end connected to the power supply,
- Remove the wall return (using a 2.5 mm Allen key),
- Disconnect the wire connector,
- Unscrew the brackets from the wall,
- Place the handrail on the floor,
- Remove the brackets and the LED band to be replaced,
- Install the new LED band according to the installation guide (see sections 6 and 7).



Offcuts and end-of-life electrical items must not be disposed of with ordinary waste, but must be sent to SPM International for recycling:

**SPM international S.A.S.
Déchet D3E
16 rue Isabelle Eberhardt
CS 92083 - 31019 Toulouse Cedex 2 - FRANCE**

spm-international.com

**PANELS
HANDRAILS
PROTECTION RAILS
CORNER PROTECTION**

ASIA: Gerflor Asia

Tel: +86 21 6357 8818 - Fax: +86 21 6357 8998

e-mail: gerflorasial@gerflor.com

AUSTRALIA/NEW ZEALAND: Gerflor Australasia Pty. Ltd

Australia Tel: 1 800 060 785 - New Zealand Tel: 0 800 630 119

e-mail: gerflor@gerflor.com.au

AUSTRIA/SWITZERLAND: Gerflor GmbH

Tel: +43 (0)72 2970 800-0 - Fax: +43 (0)72 2970 800-218

e-mail: austria@gerflor.com - switzerland@gerflor.com

BELGIUM/LUXEMBURG: Gerflor Benelux

Tel: +32 (0)3 766 42 82 - Fax: +32 (0)3 766 29 14

e-mail: gerflorbel@gerflor.com

CANADA: Gerflor International

Tel: +1 438 333 0752 - Fax: +1 438 380 5425

e-mail: gerflorcanada@gerflor.com

CHINA: Gerflor floorings (China) Co. Ltd.

Tel: +86 21 6357 8818 - Fax: +86 21 6357 8998

e-mail: gerflorchina@gerflor.com

FINLAND: Gerflor Oy

Tel: +358 (0) 10 6 17 5150 - Fax: +358 (0) 10 617 5152

e-mail: info@gerflor.fi

FRANCE: SPM International

Tel: + 33 (0)5 34 39 41 00 - Fax: +33 (0)5 34 39 40 10

e-mail: export@spm.fr

GERMANY: Gerflor Mipolam GmbH

Tel: +49 (0)22 41-25 30-0

e-mail: gerflormipolam@gerflor.com

Kunden-Service

Tel: +49 (0) 22 41-25 30-136 - Fax: +49 (0) 22 41-25 30-100

e-mail: kundenservice@gerflor.com

SAT Service und Anwendungstechnik

tel: +49 (0)22 41-25 30 555 - Fax: +49 (0)22 41-25 30 550

e-mail: technik@gerflor.com

ITALY: Gerflor S.p.A.

Tel: +39 02 90 40 10 - Fax: +39 02 90 42 74 84

e-mail: gerfloritalia@gerflor.com

LATIN AMERICA (Brazil): Gerflor América Latina

Tel: +55 11 38 48 20 20

e-mail: gerflor@gerflor.com.br

MIDDLE EAST: Gerflor Middle East

Tel: +966 13 847 1779 - Fax: +966 13 847 1781

e-mail: info@gerflorme.com

NETHERLANDS: Gerflor Benelux

Tel: +31 (0)40 266 17 00 - Fax: +31 (0)40 257 46 89

e-mail: gerflornl@gerflor.com

OTHER COUNTRIES: SPM International

Tel: + 33 (0)5 34 39 41 00 - Fax: +33 (0)5 34 39 40 10

e-mail: export@spm.fr

POLAND: Gerflor Polska Sp z o.o

Tel: + 48 61 823 34 01 - Fax: + 48 61 823 34 33

e-mail: info@gerflor.pl

PORTUGAL: Gerflor Iberia, SA

Tel: +351 21 843 95 49 - Fax: +351 21 846 55 44

e-mail: gerflorportugal@gerflor.com

RUSSIA: Gerflor zao

Tel/Fax: + 7 495 785 23 71

e-mail: gerflorrussia@gerflor.ru

SCANDINAVIA: Gerflor Scandinavia a.s.

Tel: + 47 64 95 60 70 - Fax: + 47 64 95 60 80

e-mail: gerflorscand@gerflor.no

SPAIN: Gerflor Iberia, SA

Tel: +34 91 653 50 11 - Fax: +34 91 653 25 85

e-mail: gerfloriberia@gerflor.com

USA: Gerflor North America

Tel: 877 GERFLOR (437 3567) - Fax: 847 394 3753

e-mail: info@gerflorusa.com



A company of **Gerflor**

Spm[®]
wall protection