

LAYING FLOOR COVERINGS WITH ELECTRICAL PROPERTIES, USING GTI EL5 CLEANTECH TILES WELDED WITH COVING

All material should be examined prior to installation for any visible defects. If there are any visible defects, please notify GERFLOR and do not begin installation without its prior approval.



Substrate & Ambient temperature
Minimum: 10° C

The laying procedure for GTI EL5 Cleantech tiles starts with the installation of entire tiles and ends with the coving made with MIPOLAM EL5 strips.

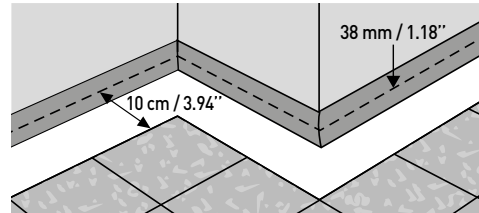

MATERIALS	FORMAT	CODE
GTI EL5 CLEANTECH	650 x 650 / Th 6 mm	2714 followed by colour code
MIPOLAM BIOCONTROL EL5	200 x 20 ml	8691 followed by colour code
MIPOLAM EL5	200 x 20 ml	8663 followed by colour code
DIMINISHING STRIP (GTI UNDERLAYER)	650 x 100	26030001
Copper strip	W (width) 10 mm / Th 0.08 mm	0586 0001
Conductive Welding rod	100 ml	2722 followed by colour code
Cove former	38 mm	4014
If installation with clean corner system:		
Outside corner		058R
Inside corner		058S
Cutting template for inside and outside corner		058T

ANTISTATIC ASTATIC FLOORINGS (ASF) < 2 kW

Standard installation. These floorings do not require any specific installation method (no copper strip required)

DISSIPATIVE (DIF) AND CONDUCTIVE (ECF) FLOORINGS

Installation using a copper strip: code 0586 0001 (length: 200 ml)
Store the tiles for 24 hours in the room where they will be installed.

REQUIREMENT SPECIFICATION FOR CONDUCTIVE FLOORINGS:

It is the responsibility of the client and/or contractor to set out the applicable standard in the requirement specification.

METHODS FOR RESILIENT FLOOR COVERINGS:

Europe: EN 1081. Transversal resistance and surface resistance on tripod
USA: ASTM F150 /NFPA 99 (2 cylindrical electrodes)

METHODS FOR ELECTRICAL INDUSTRIES:

Europe: CEI 61340-4-1
USA: ANSI/ESD S 7.1
For all other methods, see technical datasheet of the flooring.

1. CHOICE OF JOINT TREATMENT

This material is laid edge to edge, **with or without** coving. For the installation of GTI EL5 cleantech without coving, see Installation Guidelines [420].

Rooms exposed to water (bathroom, kitchens...)	Joints hot welded with conductive welding rod + caulked at the edges (leave a 3 mm gap to apply mastic)*
Rooms with prolonged exposition to water	Joints hot welded with conductive welding rod + coving

* Skirting must be installed after the flooring is laid.

2. LAYING

Preparatory work:

The tiles must be stored in the room in which they are going to be laid for 24 to 48 hours before installation. After installation, the temperature variation must not exceed 20 °C.

SUBSTRATE: Moisture content 4% at 4 cm with a carbide bomb test. To guaranty good conductivity between tiles, ensure that the surface evenness is < 7 mm under a 2m straight edge and < 2 mm under a 20 cm straight edge, with no unevenness.

MECHANICAL PREPARATION: The surfaces should be prepared with care so as to remove any soiling, laitance, treatment products or any other foreign bodies.

BUMP AND DEPRESSION TREATMENT: Sanding of bumps. Point levelling of depressions with a suitable floor sealer.

CRACK TREATMENT: On any surface, cracks should be detected beforehand. They are not treated if there is no unevenness and if they are < 3 mm wide.

JOINT TREATMENT: Contraction joint: if gap < 4 mm, they are not treated. Structural Expansion Joint: following thorough cleaning, expansion joints are preserved: end profiles with or without an overlay are arranged on either side of the joint. Construction joint: similar to cracks, not treated if gap < 3 mm.

LOCALISED LEVELLING: Surface levelling may be required, particularly where the surface is not even enough or in poor condition.

2.1 - MARKING OUT AND LAYING THE STRIPS

- Mark out a line **around the room 10 cm** from the wall in all places, using a skirting scribe or a template on the wall. This 10 cm space will be used for coving later
- **Do not use a chalk line as it will not follow the line of the wall**
- **Mark out the two perpendicular axes, making sure the cuts are the same on each side**
- Apply the tackifier or acrylic glue evenly over the two axes with a coverage of about 100 to 150 g/m²
- Apply a tackifier strip or double-sided adhesive (Fix and Free 100) under each row of tiles, in one direction only, to ensure that the tiles are held in place during chamfering and welding.
- Respect the waiting time according to the manufacturer's instructions
- Install one copper strip **every 3 rows, in one direction**, holding it down with adhesive tape (see diagram)
- **Place a copper strip UNDER the cut tiles when installing them**
- Leave some extra length at the end (about 50 cm) so it can pass under the skirting and the electrician can connect it to earth (one for every 40 m²)
- The copper strip might be visible later due to telegraphing

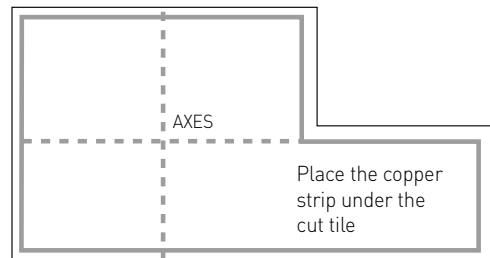

Self tape copper strip is not permitted.

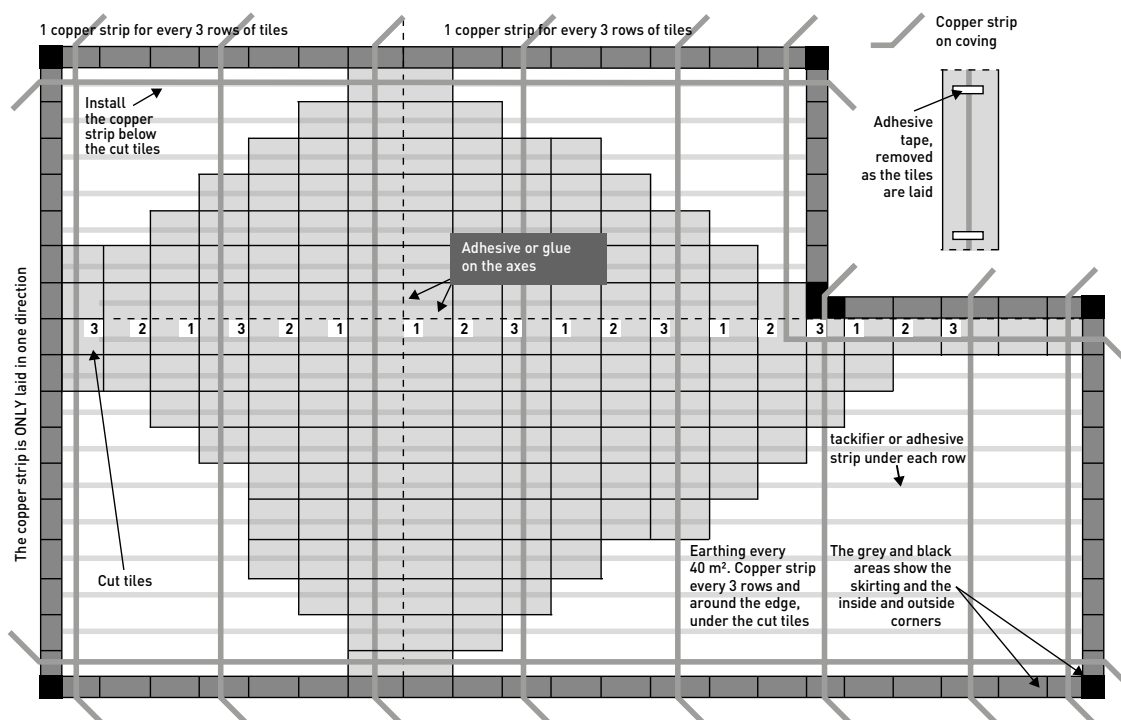

LAYING FLOOR COVERINGS WITH ELECTRICAL PROPERTIES, USING GTI EL5 CLEANTECH TILES WELDED WITH COVING

2.2 - LAYING THE UNCUT TILES

• Precautions

- 1- The tiles are supplied on pallets. Different batches must not be mixed together.
- 2- Laying direction: tiles are ALL installed in the same direction. Observe the direction indicated by the arrow on the back of the tile.
- 3- Pressed materials, such as GTI tiles, may have dimensional tolerances from one series to another or from one color to another which may vary by 1 mm. In this case, the tiles may slightly offset. It is therefore necessary to cross-cut the entire row of tiles before continuing the laying. These two rows will be hot-welded.
- 4- To allow a proper welding process, the tiles are maintained with double sided adhesive (Fix and Free 100) or tackifier.
- 5- Loose laying is limited to 500 m². Above 500 m² it is necessary to divide the surface into 500 m² sections by applying either an extra large double-sided adhesive tape (Fix and Free 750) or by gluing over a width of two tiles before laying the copper strip and the tiles. For details, see installation guideline [413] GTI Max Connect, section 2.3.1

• Installation

Lay the first tile and continue in a staircase pattern, following the axes you marked out. The tiles should be installed with a space between them of 0.8 to 1.2 mm.

Remove the adhesive tape maintaining the strip as you work.

The copper strip must always be in direct contact with the back of the tiles.

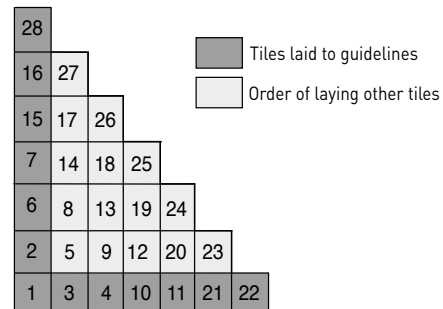
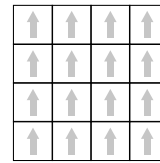

2.3. POSITIONING THE CUT TILES

The cut tiles must extend beyond the edging line you marked out.

Mark out the edging line on the tiles using a skirting scribe or a template on the wall. Make sure that there is no cutting less than 1/2 tile.

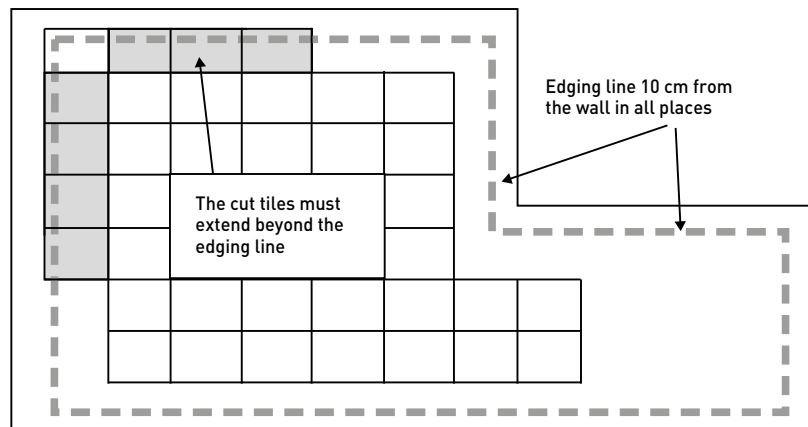

2.4. EDGING THE CUT TILES

Use a cutter (make one or two marking cut on the surface before snapping the tile).

To help, you are recommended to heat the material with a hot-air paint stripper. Using this method, no jigsaw is necessary.

The tiles must be cut along the edging line marked out on the tiles, maintaining a distance of 10 cm from the wall in all places.

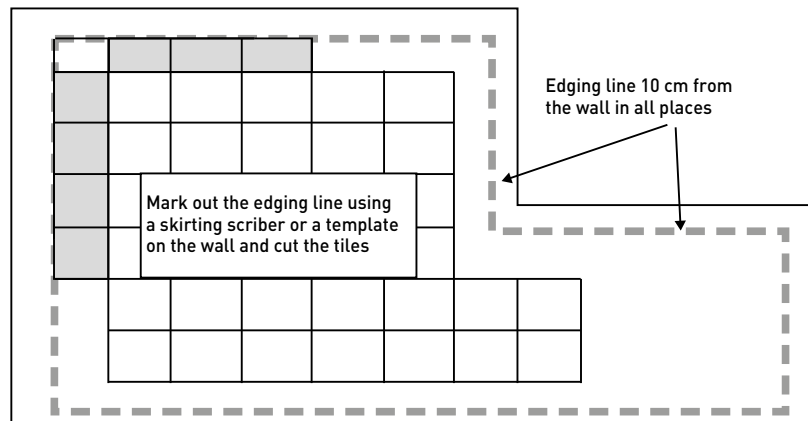

3. COVING INSTALLATION

The coving is realised with strips of Mipolam EL5 applied to the peripheral 10 cm space.

As the thickness of Mipolam is less than the thickness of the GTI slabs, it is necessary to first lay diminishing strips (GTI underlayer) all around the perimeter of the room.

For the installation of the coving, refer to the laying instructions «coving system» and «Clean Corner System in and out».

3.1. MARKING AND LAYOUT

Mark out a line around the room 10 cm from the wall in all places, using a skirting scribe or a template on the wall.

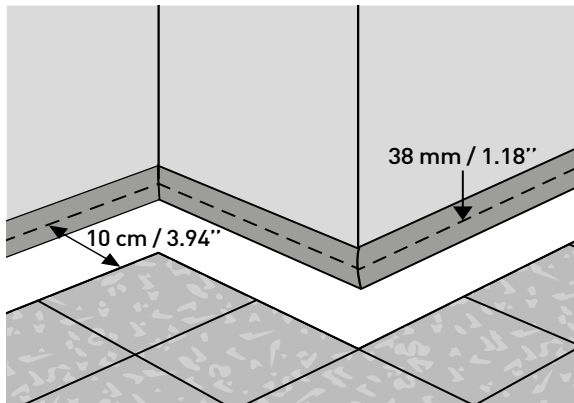

- Do not use a chalk line as it will not follow the line of the wall.
- On the walls, draw a straight line to mark out the top of the coving (maxi 15 cm).
- Place the GTI Underlayer along the edges of the room, with the glossy side on the substrate.
- Fix the cove former using acrylic glue or double sided tape ensuring the good quality of grouting in the corners (cut using a mitre box or shears).
- Glue or maintain the piece of MIPOLAM EL5 up into the coving.

No glue between the back of the flooring and the copper strip. The copper strip must be in direct contact with the reverse side of the flooring.

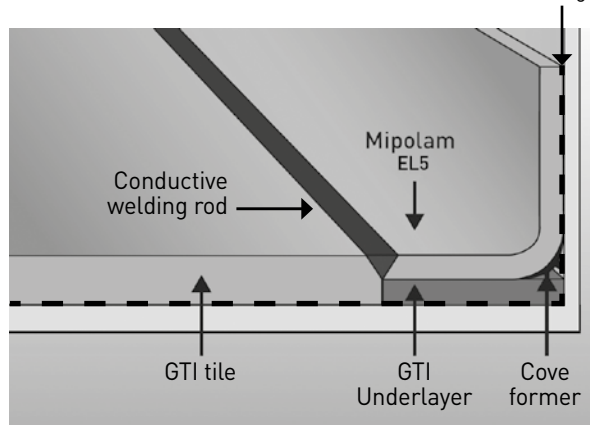

--- Copper strip on coving

4. HOT WELDED JOINTS

START BY WELDING THE SKIRTING

The tile joints are welded with a two-layer conductive welding rod.

The conductive welding rod leaves a black thread after levelling. This thread provides conductivity between each tile.

IMPORTANT :

- The trimmed conductive welding rod may leave marks on the flooring. You are recommended to collect the removed pieces as you work.
- To prevent poor welds where the tiles intersect, it is necessary to chamfer, weld and level in one direction before repeating in the other direction.

TO AVOID CALAMINE DEPOSITS DURING THE WELDING PROCESS WE RECOMMEND :

- to respect a welding temperature of 400-500°C
- to respect the recommended welding speed : position 3
- to clean the nozzles regularly

4.1. WELDING THE SKIRTING

- **Chamfer the joints** with the triangular grooving tool and the cutter for corners:

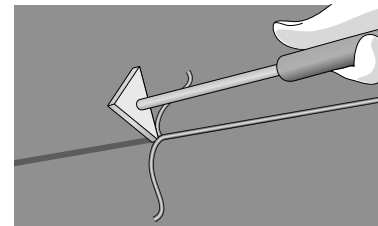

- **Hot weld the joints** using a Triac S hot air tool. Use a hooked Rapid Ultra nozzle. Clean the nozzles regularly to prevent the formation of deposits along the seam. We recommend the hooked Rapid Ultra nozzle: JANSER code 224 800 013 or ROMUS code 95028

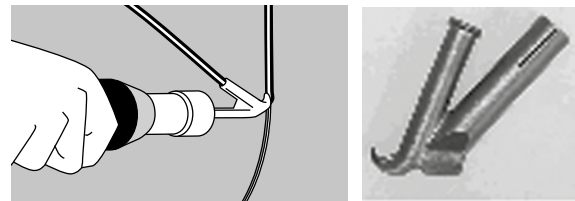

- **Trim the seam** after it has cooled down using a special skirting tool. Do not leave the trimmed welding rod on the ground. Collect it as you work to avoid any mark on the floor. We recommend a tool that has been specially designed for skirting: ROMUS code 95103

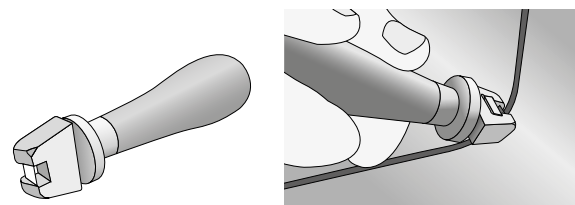

LAYING FLOOR COVERINGS WITH ELECTRICAL PROPERTIES, USING GTI EL5 CLEANTECH TILES WELDED WITH COVING

4.2. FLAT WELDING

- **Chamfer the joints** using an electric chamfering machine, blade width 3.3 mm, depth 1.5 to 1.8 mm.

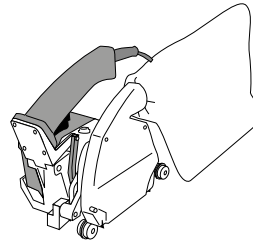
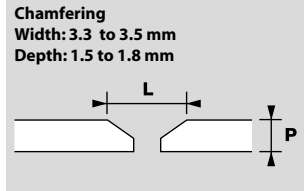
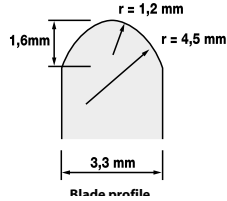

Chamfering machine

- **Hot weld the joints** using a welding machine. Use a LEISTER UNIVERSAL or UNIFLOOR hot air welding machine with electronically controlled heating, fitted with a narrow multi-outlet nozzle designed for this purpose.

TOOLS	ROMUS CODE	JANSER CODE	LEISTER CODE
Narrow nozzle	95254	225 860 040	105 407

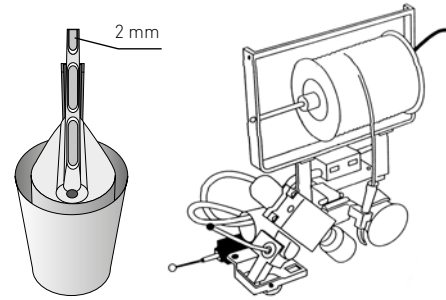

Narrow nozzle

- **Trim the seam using a mozart knife**

First pass: make an initial cut by placing the levelling guide under the MOZART knife blade (fig. 1).

Second pass: allow the seam to cool down completely

Rotate the levelling guide to 90° on the side and make a second pass to completely remove the excess seam material (fig. 2).

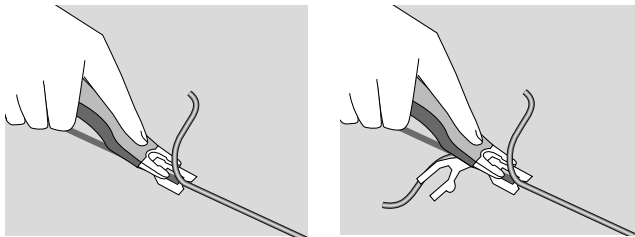

Fig. 1 - Levelling guide under the blade Fig. 2 - Levelling guide at 90°

TOOLS	GERFLOR CODE
MOZART knife	95130
Spare blades	95129

This method prevents hollow welds.

4.3. JOINING OR REPAIRING WELDS

To prevent carbon black build-up during repairs:

- Make an initial levelling cut of the seam,
- Clean the joint with a vacuum cleaner to remove the particles and run a triangular scraper over it,
- Make a notch at both ends of the seam,
- Use a hot air tool with the Rapid nozzle as explained above, starting and ending at the existing welds (about 5 cm).

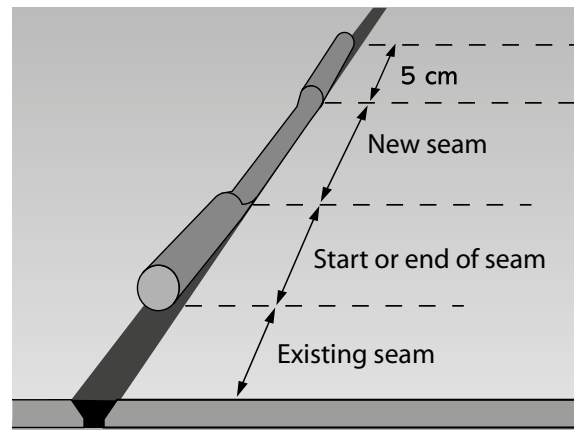

5. ENDS AND DOORWAYS

Use the following profiles depending on conditions of use (traffic, humidity...):

■ 5.1 - HEAVY TRAFFIC, PALLET TRUCKS...

Finishing profile H0505

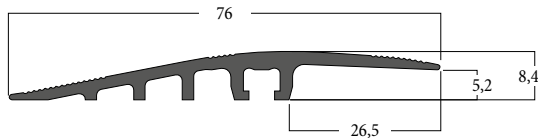

3 m long profile with 10 drilled holes of 4.3mm diameter

The centre distance between the holes is 313mm

The first hole is 90mm from the end

Deburr the holes after drilling

TFZ 4x50 mm screw and 6x30 mm plug

TFZ screw, diameter 4mm and length 50mm



Dowel, diameter 6mm and length 30mm



■ 5.2 - MODERATE TRAFFIC

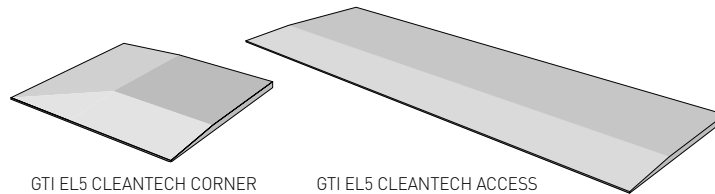

GTI EL5 CLEANTECH ACCESS AND CORNER		
GTI EL5 CLEANTECH ACCESS	650 x 320 mm	Code: 2715 followed by colour code
GTI EL5 CLEANTECH CORNER	320 x 320 mm	Code: 2716 followed by colour code

These accessories must be glued down, either using a 2 components PU adhesive and weighted until the adhesive sets (6 to 12 hours), or using an acrylic double bonding adhesive.

6. FIRST USE

- For normal traffic, the floor can be walked on immediately after welding.
To move furniture, lay panels to distribute the load.
- Do not allow rubber feet to be used on furniture.

7. UNDERFLOOR HEATING

Underfloor heating should be turned up gradually over the seven days after the flooring is laid.

8. MAINTENANCE

FINAL CLEANING

The floor covering can be used as soon as it is laid, but take these precautions:

Deposits or scuffing remains from the seam : dampen a clean cloth with alkaline detergent and gently rub to clean the marks, then wipe with a sponge dampened with clean water.

DO NOT ATTEMPT TO CLEAN BY HAND OR USING A DRY CLOTH

After the marks are removed, flooring must be cleaned as follows:

- Remove dust and particles using a broom or an industrial vacuum cleaner,
- Clean the floor with a scrubber drier using an alkaline detergent,
- Rinse with clean water to remove all traces of the detergent,
- Let it dry.

DAILY CARE

Refer to the maintenance guidelines for this flooring.