

Gerflor recommends to follow and apply local regulations and standards for the installation of the products. In case of absence of installation rules, the recommendations below can be followed. Including custom signage on the rounded stair nosing.

Before laying the flooring, check the material to identify any problems with the appearance. If there are visible defects, please notify GERFLOR and wait to hear from them before laying the flooring. In order to have the best uniformity between the stairway and the landing, we recommend to use the same batch of flooring.

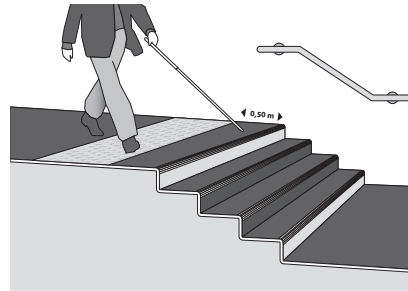
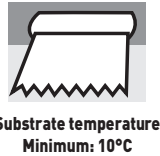
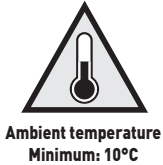

GLUING FULL WIDTH STEPS

Do not use solvent based neoprene adhesive to glue down the steps.
We recommend a **water-based contact adhesive**.
The stair nosing must be rounded off to a curve radius of at least 12 mm.

1. INTRODUCTION

The materials are available in lengths of 100 cm to cover two winders or two straight steps. Two finishes are available for the corner between the tread and the riser:

- **Step clip** (clip-on finishing profile).
- **Cold welding**.

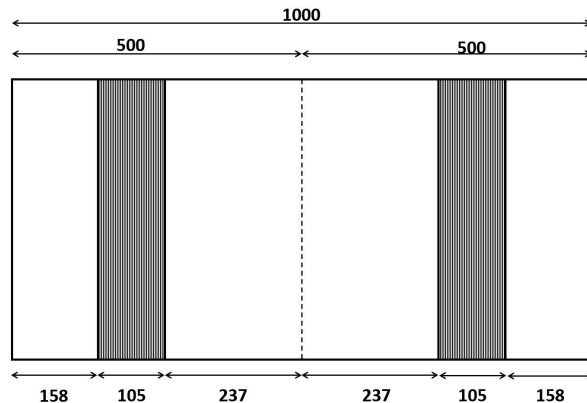

2. PREPARATION

2.1 - SUBSTRATE

The substrate should be flat, sound, smooth, clean and dry. The curve radius of the stair nosing must be at least 12 mm. Carefully level the tread and the riser using a skimming compound that has been described in a technical report. A non-drip, thixotropic compound is recommended for the riser.

2.2 - STAIR NOSINGS

2.2.1 - Protruding stair nosing

Finish with a filler under the protruding part.



2.2.2 - Stair nosing with sharp corner

Work over the corner several times to round it off to a 12 mm minimum curve radius.

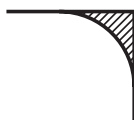

2.3 - PREPARING STAIRS

2.3.1 - Treads and risers

If the substrate is absorbent, apply a primer that is suitable for use with the particular adhesive.

2.3.2 - Back of tread (if finishing clips are used: Ref H 158)

- Glue the base of the clip in the corner between the tread and the riser.

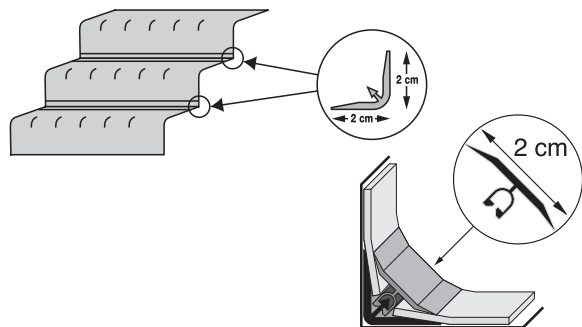

■ 2.4 - LAYING FULL-WIDTH STEPS

2.4.1 - Marking the stair nosing:

Draw a line along the middle of the stair nosing.

2.4.2 - Prepare the full-width steps

2.4.2.1 - Cutting

- The day before laying, cut the flooring to the stair dimensions lengthwise, plus 5 cm.

2.4.2.2 - Prepare the contrasting risers

The first and last step must have a riser at least between 10 cm and 16 cm in height, which contrasts visually with the tread.

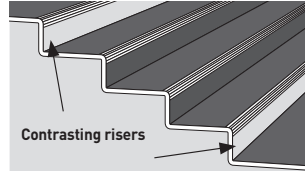

Riser included between 10 and 16 cm

Hot welding

Tread



Gerflor supplies two products:

- Welded fitted strips using the same product in a different colour.
- Contrasting adhesive strips (see 5.2).

Welded fitted strips:

Prepare these steps before installing them.

- Before installation, cut the riser between 10 cm and 16 cm to create a **visual contrast** with the tread.
- Cut the same shape in the contrasting material, using the cut as a template.
- Hot weld the two floor coverings on the flat before fitting the step.

2.4.2.3 - Mark out the floor covering

Use a pencil to draw a line on the back of the cut floor covering 2/3 of the way into the textured section (see diagram : line A).

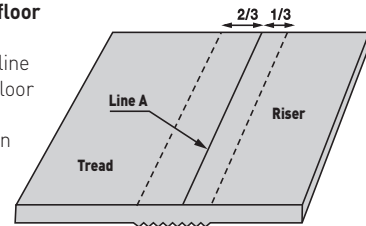

3. LAYING FULL-WIDTH STEPS

■ 3.1 - GLUING

Gerflor does not recommend using solvent based neoprene adhesive

Gerflor recommends to use a water-based contact adhesive according to its technical data sheet.

Usual rules are: After adhesive's mixing, apply the adhesive on both surfaces (back of the flooring and stair) with spatula or brush.

Consumption: 150 g / m² / surface.

For absorbent support, it may be necessary to apply 2 layers of adhesive.

Let dry the adhesive until there is no adhesive transfer to fingers (approx. 5 to 10 min according to conditions) before laying the flooring.

The use of double-sided adhesive may be used in accordance with the adhesive manufacturer's recommendation.

■ 3.2 - LAYING THE STEPS

- Start laying the flooring at the bottom of the stairs.
- After the specified drying time, roll up the flooring, position it on

the stair nosing, then unroll it making sure it is lined up with the marking on the stair nosing: line along the middle of the stair nosing (§2.4.1) and line A on the back of the cut floor (§2.4.2.3).

- Smooth out the material very firmly in the following order:
 1. the tread texturing, lengthwise;
 2. the tread, from the centre to the edges;
 3. the rounded part of the texturing, from the riser downwards;
 4. the riser itself, from the centre to the edges.
- 5a. Step clip: Cut the floor covering in the tread/riser corners on the base of the clip, leaving 2 mm on each side of the pin.
- 5b. Cold welding: Cut the floor covering in the tread/riser corners.

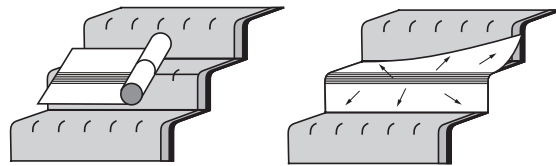

4. JOIN WITH THE LANDING

- The treads of the top steps are cut where the stair nosing texturing starts, to avoid a colour difference with the material laid on the tread. Tint or gloss level may be discernible between landing and step.
- The stair nosing and landing floor covering are joined by hot welding with a round cord CR40.

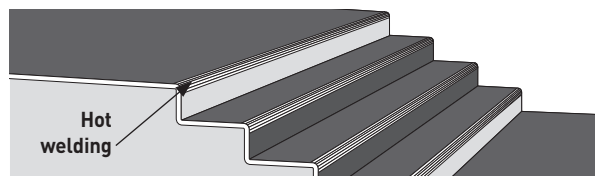

5. FINISHES

5.1 - BACK OF TREAD

5.1.1 - Step clip

- Insert the clip-on profile in the base by pressing down.

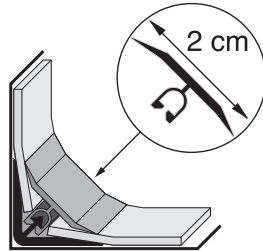

5.1.2 - Cold welding:

- See the diagram opposite.

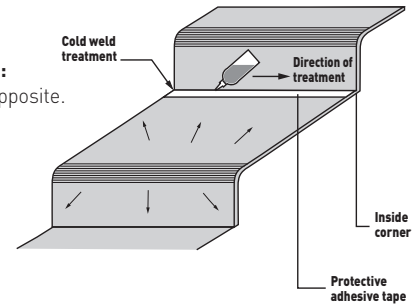

5.2 - CONTRASTING ADHESIVE STRIP ON THE RISERS

- Clean
- Pull off the protective film
- Apply the adhesive strip at the bottom of the riser
- Cut away the excess material

PRODUCTS	DIMENSION	GERFLOR CODE	REFERENCE
ADH. RISER 10 CM X 10 ML	10 cm x 10 ml	058M	0001 white 0003 black 0005 yellow

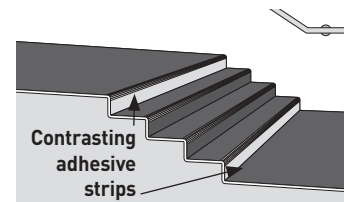

6. FIRST USE

12 to 24 hours after laying depending on the specified gluing method (see the technical report for the adhesive).

7. OTHER STAIRCASE TYPES

- Spiral staircases: create a central passage.
- Metal stairs with riser (rounded nosing). Strip fully, exposing the metal.

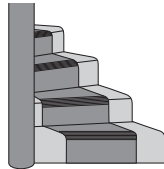

Full-width steps cannot be used in these three cases:

- Staircase with convex or concave steps.
- Staircase with metal stair nosings: if there is a sharp corner or if there is no riser.
- Staircase without risers.

Use a floor covering in rolls or tiles with a fitted stair nosing profile.

8. WARNING STRIPS

At the top of the stairs, the floor covering must create a visual and tactile contrast in order to provide a warning at a distance of 0.50 m from the first step.

8.1 - SELF-ADHESIVE TACTILE TILE:

1. Remove grease if necessary
2. Mark a line 50 cm from the stair nosing
3. Position the self-adhesive tactile tile at the reference 50 cm
4. Smoothing with a 50 kg minimum roller.

Tile dimensions: 1363 x 426 mm - 838 x 426 mm

PRODUCTS	DIMENSIONS	GERFLOR CODE	REFERENCE
ALERTILE 1363 x 426 - 4 UNITS	1363 x 426 mm	059A	0200 Light Grey 0300 Dark grey - 0400 Yellow
ALERTILE 838 x 426 - 10 UNITS	838 x 426 mm	059B	0200 Light Grey 0300 Dark grey - 0400 Yellow

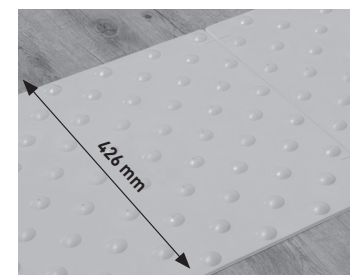
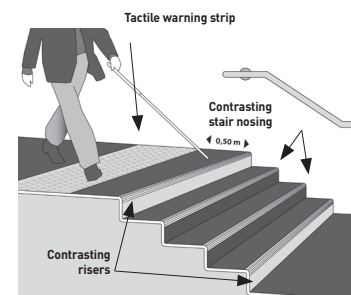

■ 8.2 - SELF-ADHESIVE TACTILE STUDS - only for CEN 23 / 33 / 41 use excluding industrial environment and rolling loads:

1. Remove grease if necessary
2. Mark a line 50 cm from the stair nosing
3. Remove the adhesive protection strips from studs and rectangles.
4. Position the edge of the studs plates on the axle and apply hand pressure on the rectangles to ensure that the assembly is in position.
5. Smoothing with a 50 kg minimum roller or trample the plate and all the studs to ensure their adhesion to the substrate.
6. Remove the plates.

NB: The plates can be clipped together to ensure perfect alignment of the studs.

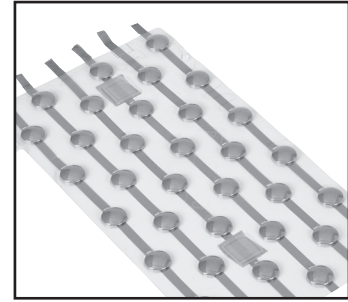

Tile dimensions: One kit can create a tile of length 1320 / width 400 mm, or 198 studs.

PRODUITS	DIMENSIONS	CODE GERFLOR	CODE RÉFÉRENCE
EASYPLOT 6 plates of 33 studs	Diam 25 x height 5 mm	059C (color) 059D (alu)	0002 Grey 0003 Black 0100 Alu

■ 8.3 - INLAID TACTILE TILE:

1. Cutting the flooring.
2. Mark the tactile tile to be inlaid on the flooring so that it is 50 cm from the edge of the stair nosing when the flooring is laid.
3. Cut out the location of the tile
4. Gluing the flooring
5. Remove the protective paper and inlay the tile.
6. Smoothing with a 50 kg minimum roller.
7. Chamfer, hot weld and trim off the excess.

Dimensions of the inlaid strip: L: 1363 / W: 426 mm or L: 838 / W: 426 mm

PRODUCTS	DIMENSIONS	GERFLOR CODE	REFERENCE
ALERTILE 1363 x 426 - 4 UNITS	1363 x 426 mm	059A	0200 Light Grey 0300 Dark grey - 0400 Yellow
ALERTILE 838 x 426 - 10 UNITS	838 x 426 mm	059B	0200 Light Grey 0300 Dark grey - 0400 Yellow