

LAYING TECHNIQUES FOR TARADOUCHE SYSTEM

GERFLOR WET AREA SEALING PROCESS



1 - WARRANTYpage 2
2 - PRINCIPEpage 2
2.1 - Definition	
2.2 - Floorings	
2.3 - Products	
3 - BUILDING REGULATIONSpage 2
4 - FLOOR DRAINpage 3
4.1 - NICOLL	
4.2 - Other drains	
4.3 - Timber substrate	
5 - PREPARING ANGLESpage 3
6 - LAYING THE FLOORINGpage 3-5
6.1 - Substrate	
6.2 - Laying method	
6.3 - Laying the flooring	
6.4 - Sealing the edges	
6.5 - Treatment of joints	
6.6 - Shower/ bedroom junction	
7 - FIXING WALL CLADDINGpage 6-7
7.1 - Substrate	
7.2 - Preparing the wall	
7.3 - Fixing the wall cladding	
7.4 - Overlaps	
7.5 - Suspended WC bowl	
7.6 - Finishing - Connections	
8 - TARADOUCHEPLUS CONFORT SYSTEM APPENDIXpage 7
9 - LIST OF SPECIAL TOOLSpage 8
10 - ACCESSORIESpage 8

**Before laying the flooring, examine it to detect any problems of a visual nature.
If there is an aspect defect, inform Gerflor and do not start laying without its agreement.**

1 - WARRANTY

• 1.1 - PRODUCT WARRANTY

Flooring should be laid in accordance with the instructions in this document, the specification current on the date of signature of the contract and in accordance with good custom and practice. If so, the flooring will be covered by the manufacturer's warranty.

• 1.2 - LAYING WARRANTY IN FRANCE

As this process is detailed in the Manufacturer's Instructions, the TARADOUCHE SYSTEM need to be in accordance with the locals warranties.

2 - PRINCIPE

• 2.1 - DEFINITION

Complete shower system based on plastic flooring and wall cladding, including the use of floor drains and falls.

• 2.2 - FLOORINGS

Flexible reinforced vinyl flooring in lengths as below.

Commercial name	Thickness	Fire rating
BRAZILIA SD	2 à 2,2 mm	B-s1
TARALAY Safety		(equivalent to M3 on MO substrate)
ELEGANCE SD		

Flexible reinforced vinyl wall cladding in lengths:

Commercial name	Thickness	Fire rating
TARADOUCHE Wall	0,9 mm	B-s2, dO B-s1, dO on M1 substrate (equivalent to M1 on M1 substrate)

• 2.3 - PRODUCTS

- floor drains
 - cove formers
 - adhesives
 - weld beads
 - reducer profile
 - sealants
 - Tarafoam 20 foam for the 'confort' version of the shower system
- All surfaces (floors and walls up to the ceiling) will be treated with this complete system.**

3 - BUILDING REGULATIONS

The relevant building regulations must be taken into account and complied with to ensure that the Taradouche Plus System is correctly installed and watertight.

• 3.1 - ABOUT SUBSTRATES

FLOOR substrate with fall to the drain (1%) at least for 1 m around and from the drain (in accordance with the contract drawings).

- Splash protection

Around the drain	1% overall	1% over 1 m (minimum)
Splash protection	NO	YES

- Right angle, well finished wall-floor angle
- Expansion joints crossing the area concerned are not allowed
- Substrates (walls / partitions)

Substrates must have no trace of damp, mould or marks (marker lines, ink, pencil or crayon markings, graffiti, etc.)

WALLS must be in accordance with the local standards

Levelness and flatness must be checked and corrected accordingly.

NB: Local flatness: 1 mm under a 20 cm rule.

- General flatness: 5 mm under a 2 m rule.
- Vertical trueness: 5 mm under a 2.5 m rule.
- Mean hardness: 45 shore C.
- Moisture content 5 % by weight

• 3.2 - ABOUT THE DRAIN

On a hydraulic substrate: the plumber is responsible for supplying and installing the drain (in the finished slab at least 30 cm from walls from the centre line of the drain) in coordination with the building and flooring contractors.

On a timber substrate: the plumber is responsible for supplying and installing the drain (at finished slab level and at least 30 cm from walls from

the centre line of the drain: fit and tighten the frame and then tighten the drain on the frame) in coordination with the woodwork / timber framing and flooring contractors.

• 3.3 - ABOUT WATERPIPES

3.3.1 - Floor

The following solutions are possible:

- Building it into the partitioning
- Running it through a utility conduit
- Running it together an adjacent room
- Concentrating it in an angle + shuttered casting
- Drop from the ceiling

The solution with Stosset connectors can be acceptable in some cases of renovation for hot and cold water feeds, wastewater from hand basins, heating pipes and vertical soil pipes from WCs, on condition that they are far enough away to avoid splash from the shower.

3.3.2 - Wall

Substrates must have no trace of damp, mould or marks (marker lines, ink, pencil or crayon markings, graffiti, etc.).

Water supply and waste pipes for future connection should be 5 cm in length at most, and the space between pipework and the wall should be 5 cm (for installing Taradouche Wall).

• 3.4 - ABOUT FITTINGS (EQUIPMENTS)

- Wall mounting for wash basin, etc
- Wall mounting advised for WC
- Horizontal wastes mandatory
- All the equipments must be remove before the laying installation et re-fitting 1 or 2 days after.

4 - FLOOR DRAIN

Installing the drain

The drain is supplied and fitted by the plumber in the finished concrete slab with the centre of the drain at least 30 cm from walls.

The following models are recommended:

• 4.1 - NICOLL - Ref : SITAR or SITAR V

Both drains are available from Gerflor.

Two outlet diameters: Ø 50 mm - Ø 63 mm

Two types: horizontal Ø 50 mm - vertical Ø 50 mm and Ø 63 mm

• 4.2 - OTHER DRAINS

Other drains with the same sealing characteristics can be used (in compliance with warranties given by the supplier on the seal).

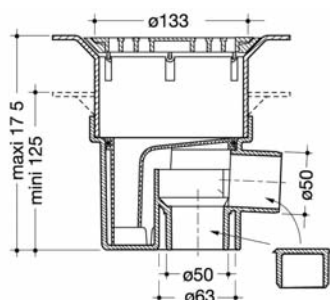

SIPHON SITAR
H112

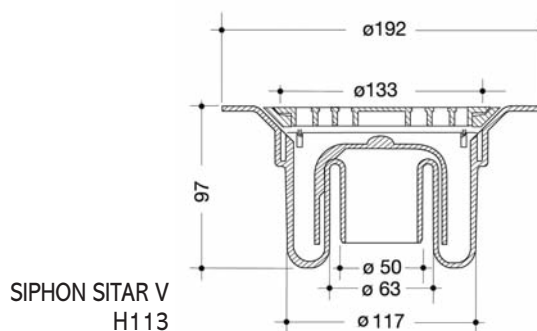

SIPHON SITAR V
H113

5 - PREPARING ANGLES

Cove former (available from Gerflor)

Cove former recommended but not mandatory unless double fitted on foam. (cove formers bonded to the foam).

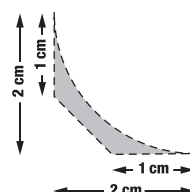

6 - LAYING THE FLOORING

• 6.1 - SUBSTRATE

Substrate must be in accordance with the local standards.

• 6.2 - LAYING METHOD

With coving for Gerflor flooring.

• 6.3 - LAYING THE FLOORING

6.3.1 - Positioning the flooring

• Minimum ambient laying temperature and substrate temperature: see local standards.

6.3.2 - Layout – Preparing lengths

- Lay the lengths out edge to edge so that welds are more than 20 cm from the drain.
- It is advisable not to have any welds in the shower area.

6.3.3 - Gluing*

- Gluing takes place 24 hours after the flooring is positioned.
- Adhesive is by simple gluing with acrylic emulsion adhesives applied using an A2 type spatula with very fine teeth (in accordance with the TKB specification) at about 300/350 g/m². Complying with this quantity requires the spatula to be changed regularly.

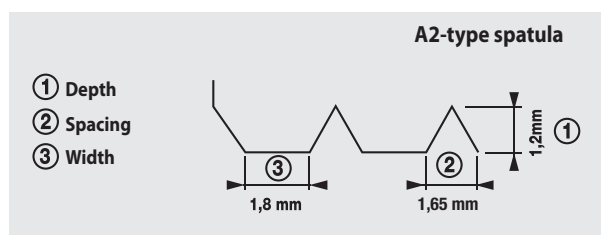

* Recommendations for gluing

- Carefully follow the adhesive supplier's instructions.
- Respect the waiting time which depends on temperature, ambient humidity, the porosity of the substrate and the quantity of adhesive.
- If flooring is applied to adhesive whose waiting time is insufficient, blisters will form.
- If flooring is applied to adhesive whose working time is exceeded, there will be poor transfer of adhesive onto the back of the material (poor bonding).

6.3.4 - Laying lengths

- Fold back half the length. Glue the substrate and apply the flooring.
- Fold back the second half and work similarly, leaving play of 1 mm.
- Do not overlap two films of adhesive when resuming gluing.

6.3.5 - Rolling out

- Careful manual sticking down at the time of laying to ensure correct transfer of the film of adhesive.

Important

- Foot traffic 24 hours after laying.
- Addition of fittings or furniture 48 hours after laying.
- Furniture with rubber feet must not be used.

6.3.6 - Flooring/drain connection seal

- Unroll and glue the Gerflor flooring up to the screw holder. Double acrylic gluing around the drain is recommended.
- Position the lengths edge to edge so that welds are more than 20 am from the drain.

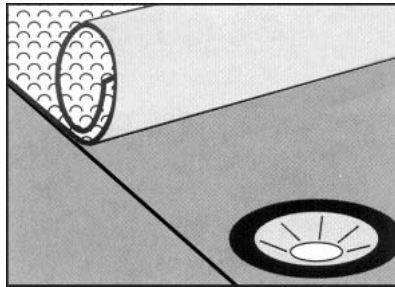

- Draw the cutting circle inside the flange positioned above the hole.

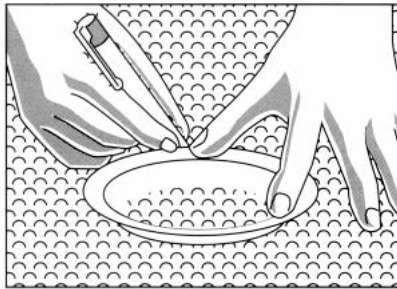

- Cut the flooring

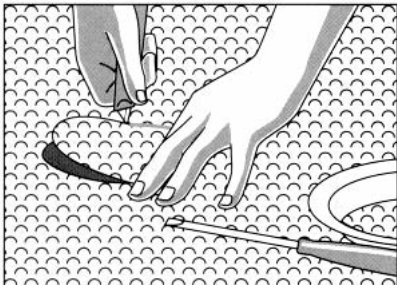

- Heat the PVC floor with a hot air gun

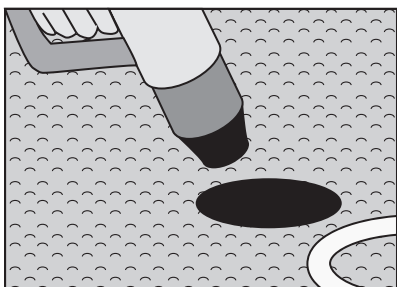

- Put the flange on.
- Fix it with screws.



• 6.4 - EDGE SEAL

6.4.1 - By coving

INTERNAL ANGLE

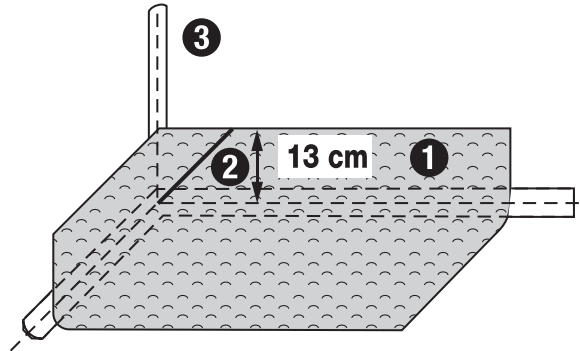

1. Glue the flooring upstand for 13 cm.
2. Cut the flooring at 45° and weld the CR 40 bead.
3. WALL angle: fix by double gluing the CA 12 bead for the full height from the coving upstand.

EXTERNAL ANGLE

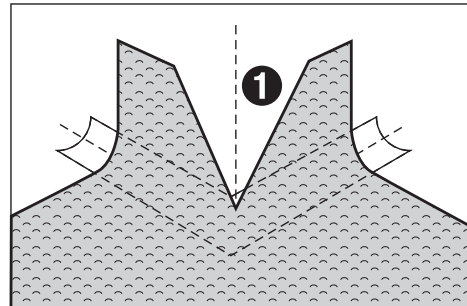

- 1- Cut the flooring up to the mid-height of the cove former.

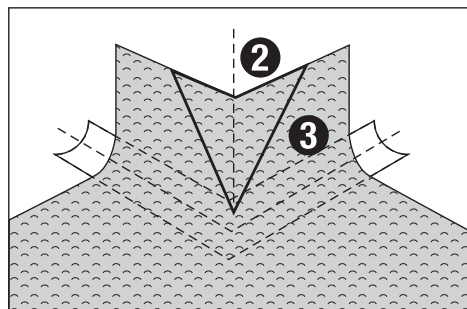

- 2- Add a piece of flooring.
- 3- Weld with CR 40 welding rope and make good.

• 6.5 - TREATMENT OF JOINTS

No welding on the drain

- Heat welding is mandatory (at least 24 h after gluing).

• Chamfering

Chamfering enables the joint to be opened and adjusted, and any traces of adhesive that affect the quality of the weld to be removed:

- it is done with an appropriate tool (triangle).
- the thickness of the flooring less about 0.3 mm should be chamfered.

Chamfer

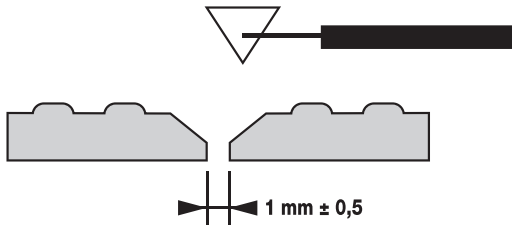

• Welding Gerflor floorings

Welding is with a Leister type controlled hot air gun fitted with a suitable speed nozzle.

It is also possible to weld with the quick nozzle (Ø 5 mm). With all types of welding equipment, follow the manufacturer's instructions.

• Trimming for Gerflor flooring

This operation should be done after the strip has cooled with:

- either a trimming gouge,
- or a flexible spatula for sealant sharpened in the middle eg: Mozart knife.

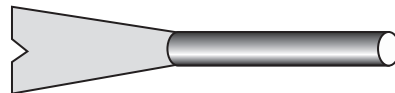

IMPORTANT!

Contact Gerflor for any further information about the material.

• 6.6 - SHOWER/ BEDROOM JUNCTION

- **Packaging:** 8 x 3 ml
- **Fixing:** Double polychloroprene bonding
- **Sealing around the base of the door frame**

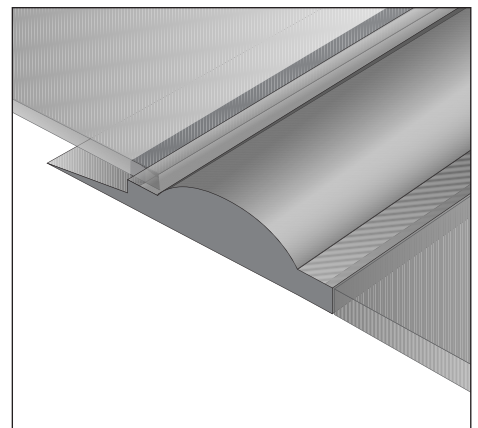
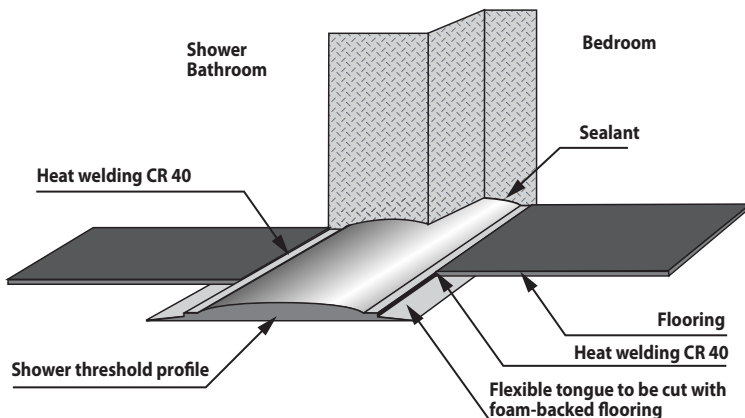
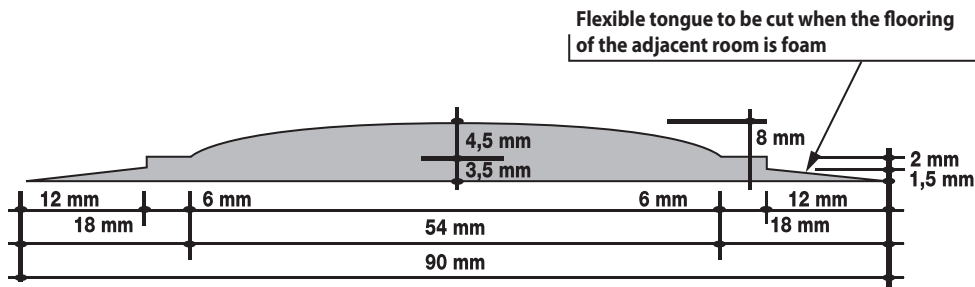

7 - FIXING WALL CLADDING: TARADOUCHE WALL

7.1 - SUBSTRATE

These claddings are fixed by gluing to a substrate built in accordance with local standards:

- The Technical Instructions for the substrates concerned,
- The Gerflor installation guide "Preparing substrates for fixing wall claddings.

Recap of requirements:

- After stripping and dust removal, the surface must not be powdery, must have no cracks, crazing, holes or scratches 1 mm or more deep.
- Local flatness: 1 mm under a 20 cm rule
- General flatness: 5 mm under a 2 m rule.
- Vertical trueness: 5 mm under a 2.50 m rule.
- Mean hardness: 45 shore C.
- Moisture content < 5 % by weight.
- Substrates and Taradouche Wall must have no trace of damp, mould or marks (marker lines, ink, pencil or crayon markings, graffiti, etc.)

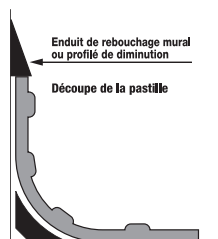

7.2 - PREPARING THE CONNECTION TO THE COVING

Projections under the overlap will be cut by means of a trimming plane or quarter moon cutter. The difference in thickness is made up for by feathering with filler or a feathering profile.

INTERNAL ANGLE: ①

Glue a CA12 rope from Gerflor in the angle before fixing the Taradouche Wall

EXTERNAL and OBTUSE ANGLES

(> à 90°) : ② ③

For external and obtuse angles (>90°), double acrylic or neoprene gluing is recommended to prevent loss of adherence over time. It is necessary to apply Gerflor S M primer on the back of the material to create a double bond in neoprene adhesive.

A primer compatible with the substrate and the adhesive will be applied to ensure uniform porosity.

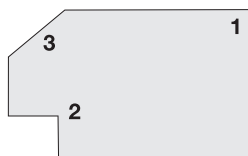

7.3 - FIXING TARADOUCHE WALL ON THE FULL HEIGHT

- If there is a false ceiling: glue the floor covering before the cornices are fitted.

7.3.1 - Fixing the material

- Minimum substrate temperature: 10°C
- Minimum ambient fixing temperature: 10°C
- Store the wall cladding at the minimum fixing temperature (15°C) for 24 hours.

7.3.2 - Drawing the initial plumb

Preparing lengths:

- Draw an initial plumb line positioned according to the dimensions of the area so as to avoid any welding near to (within 10 cm) or at an angle. Draw a second vertical the width of a panel away to determine the area to be glued.
- Measure the height of the wall to be clad.
- Cut the lengths allowing a surplus.

7.3.3 - Gluing

Application as a single coat of aqueous phase dispersion adhesive (acrylic) with a type A4 fine toothed spatula (in accordance with TKB recommendation) and crossed with a medium length pile roller or applied directly with the medium length pile roller.

* Recommendations for gluing

- Follow the adhesive supplier's instructions meticulously.
- Respect the waiting time which depends on temperature, ambient humidity, the porosity of the substrate and quantity of adhesive.

7.3.4 - Bonding the substrate and fixing the lengths

Evenly and uniformly glue the wall with an acrylic adhesive at 150 to 200gr /m².

INTERNAL ANGLE: ①

Glue a CA12 bead in the angle before positioning the Taradouche Wall

EXTERNAL and OBTUSE ANGLES

(> à 90°) : ② ③

For external and obtuse angles (>90°), double acrylic or neoprene bonding is recommended to prevent loss of adherence over time. It is necessary to apply a Gerflor S M primer on the back of the material to create double bonding with neoprene adhesive.

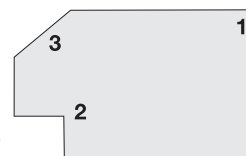

7.3.5 - Rolling out Sticking down

a) On initial contact

Eliminate air from top to bottom and from the centre to the edges using a cork block.

For external angles:

- Stick down up to the angle.
- Work around the flooring sticking down the angle with a cloth and finishing with the external angle roller.

For internal and obtuse angles:

Fix the cladding using the internal angle roller.

b) Final sticking down

With paint stripper gun or Leister Electron + cork block.

7.3.6 - Treatment of joints (24 hours after gluing)

Fixing the lengths	TARADOUCHE WALL: Spacing between lengths: 1 mm + 0.5 — 0mm	
	Tools	Use
Chamfering	Ensure joints are even. Eliminate traces of adhesive which affect the fusion of the welding bead	
	Triangular scraper	The thickness of this material means that each length has to be chamfered separately with a triangular scraper tilted right and left. This method increases the contact area of the CR 41 rope when welding.
Welding	Hot Jet S type fitted with a Rapid Ultra nozzle	CR 41 bead. Air propulsion: position 4 (80 l of air/ mn) Temperature: 450 to 500°, position between 4 and 5.
	Leister Triac fitted with a Rapid Ultra nozzle	Hot air: 230 l /mn. Temperature: position between 4 and 5. The nozzle should be cleaned after every weld.
Trimming	Slim or Mozart spreading spatula 1/4 moon cutter + trimming guide	Use a spreading spatula sharpened in the middle so as not to cut into the material.

• 7.4 - LAPPING THE COVING

The wall cladding overlaps the flooring coving by at least 3 cm. The Taradouche Wall is glued to the coving with an acrylic adhesive.

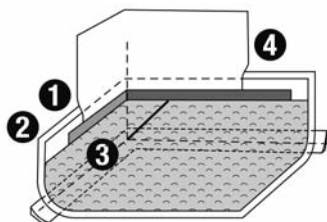

1 : The difference in thickness is made up for by feathering with filler or a feathering profile.

2 : Remove projections with a 1/4 moon cutter over 3 cm.

3 : Protect cladding under the overlap with masking tape.

4 : Apply the adhesive. Remove the masking tape before applying Taradouche Wall

Heat and stick down Taradouche Wall on the overlap with a flat roller.

• 7.5 - SUSPENDED WC BOWL

- This type of fitting should be installed in accordance with the XP D 12-208 bathroom fitting & frame-substrate standard.
- Panel of BA 13 panels should be glued together and fixed directly to the frame-substrate.

NOTE: Taradouche Wall must be glued and fixed with particular care around WC fittings and must comply with our recommendations.

NB: A 4 spatula, coverage about 150/200 g/m², crossed with a medium length pile roller, final sticking down with paint stripper gun and cork block.

• 7.6 - FINISHING - CONNECTION WITH UTILITIES

Taradouche Wall must be glued, cut and finished around the building's utilities and services with particular care and must comply with our recommendations

7.6.1 Wall fittings

The sealing of wall fittings should be part of the plumbing work included in the contract and done when wash basins, shower cabinets, wall waste pipes, grab handles and inspection eyes are installed.

sealant - ref: Bostik Simson 007 or Sika Sikaflex

7.6.2 - Services through walls (heating, plumbing)

Sealing services through walls should be included in the contract's plumbing work

Heating and water pipes for showers and basins – Soil pipes – Heating

sealant - ref: Bostik Simson 007 or Sika Sikaflex

7.6.3 - Bathroom edges

Bottom of the door frame – window - casement – Around the false ceiling (when Taradouche Wall is fitted afterwards).

sealant - ref: Bostik Simson 007 or Sika Sikaflex

Door threshold

heat welding with the plastic cladding in the adjacent room or to the shower threshold profile (bedroom, corridor) see paragraph 6.6

7.6.4 - Electricity

Switch - Socket

Minimum distance (in France) between an electric point and a fixed shower head or shower hose attachment: 1.20 m.

7.6.5 - Ventilation

Natural: low inlet / high outlet

Mechanical: wall / ceiling outlet

sealant - ref: Bostik Simson 007 or Sika Sikaflex

7.6.6 - Special cases - Renovation (see chapter 3.3.1 sol)

Horizontal and vertical pipe runs – Fixing bathroom fittings.

Grouped services

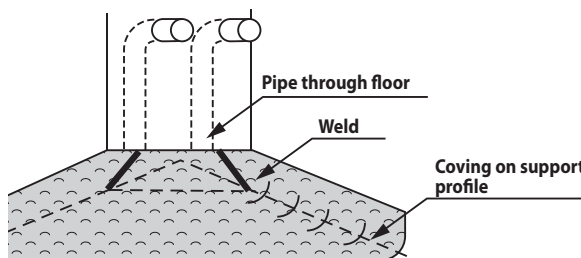

Special case – Use of Stosset connectors

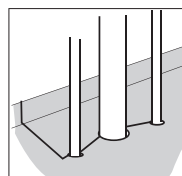

Cutting and welding the material around pipes

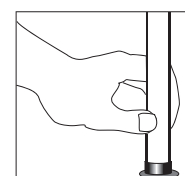

Sealing and installing the connector

8 - APPENDIX TO THE TARADOCHEPLUS CONFORT SYSTEM

• 8.1 - FITTING SOUNDPROOF UNDERLAY

- Only for fitting Brazilia S D
- Tarafoam underlay is installed 24 hours at most before the shower flooring.
- It is laid with square edges
- The foam is glued with an aqueous phase dispersion adhesive (acrylic) applied with a TKB standard A 2 spatula
- Cut and make good around the edges
- Cut around the drain, allowing about 1 cm
- Glue the cove former to the Tarafoam underlay

• 8.2 - LAYING FLOORING

Glue flooring to the underlay using a compact/compact acrylic adhesive at 200 to 250 g/m² with the type A5 spatula (TKB specification), then flatten ridges in the adhesive with a medium length pile roller. (The waiting time must be complied with for this type of gluing). Fix the cladding following the same principle as with the TaraDouchePlus System.

9 - LIST OF SPECIAL TOOLS

JANSER S.A.
www.janser.fr





ROMUS
e-mail : commercial@romus.fr

WOLFF
www.wolff.fr

	GERFLOR	JANSER	ROMUS	WOLFF
TRACER FOR COVING - 200 mm substrate bead		Réf. : 222 430 100	95430	
ADHESIVE SPATULA WITH INTERCHANGEABLE BLADE (18 CM)	0545 0001			
A 2 BLADE TKB STANDARD	0547 0001			
A 4 BLADE TKB STANDARD	0536 0001			
PRESSURE ROLLER - steel Ø 30 x 45 mm		Réf. : 224 400 125		111 200 000
COVING RULER - For cutting flooring 13 cm and 10 cm from the floor, for coving		Réf. : 224 432 000		
CORK BLOCK FOR BONDING	0528 0001	Réf. : 262 380 000	93145	720 930 000
COMBINED TRACER AND MARKING GAUGE - (spur 1 mm thick)		Réf. : 262 130 500	09335	
SPARE BLADE (in 5s)		Réf. : 262 415 001	93356	
SPARE POINT Ø 1.5 mm (in 20s)		Réf. : 262 126 000	93357	
ROLLER FOR INTERNAL ANGLE	0529 0001	Réf. : 224 400 123	093135	116 340 000
ROLLER FOR EXTERNAL ANGLE	0544 0001	Réf. : 262 614 000		116 350 000
COVING FINISHING TOOL	0562 0001			
HOT CHAMFERING GOUGE FOR TARASFE	0569 0001			
ULTRA FAST NOZZLE	0563 0001	Réf. : 224 800 007		
TRIANGULAR SCRAPER with interchangeable blade	0543 0001	Réf. : 262 607 000	95185	721 030 000
SPARE BLADE		Réf. : 262 627 001		721 031 000
FINISHING SPATULA – For finishing flooring with projections		Réf. : 262 609 100		116 400 000 116 402 000
PRESSURE BALL - Brass – Ø 13 mm – For rounding joints in angles		Réf. : 224 816 000		116 200 000
ROUNDED BALDE Ø 4 mm – For sharpening finishing spatulas and cleaning nozzles		Réf. : 262 609 102	95191	

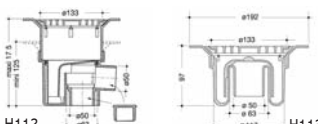
10 - ACCESSORIES

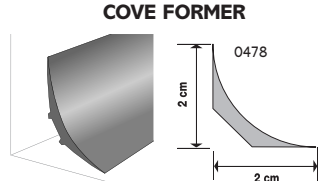
• 10.1 - ACCESSORIES AVAILABLE FROM GERFLOR

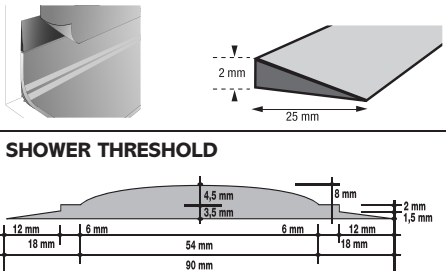
DRAINS: SITAR or SITAR V 	ANGLE BEAD CA 12 
 TARADOUCHE WALL PRIMER H 102 0001	COVE FORMER 
FEATHERING PROFILE 0490 	

• 10.2 - OTHER RECOMMENDED ACCESSORIES, NOT AVAILABLE FROM GERFLOR

SEALANT	BOSTIK SA Tél. : 01 64 42 12 12 Réf. : SIMSON 007 Solvant AK BOSTIK
	SIKA 84 rue Edouard Vaillant 93350 LE BOURGET Tél. : 01 49 92 80 33 Fax : 01 49 92 80 97 Réf. : Mastik SIKAFLEX 221 Primaire : 215 Cleaner : 205