

# LAYING TECHNIQUES FOR TARASTEP

includes instructions for installing visual signalling in rounded stair nosings as per DGUHC circular 2007-53 dated 30 November 2007



Ambient temperature  
Min. 10°C



Floor temperature  
Min. 10°C

**Always check the material before starting work in order to avoid problems with visible defects.  
Please inform GERFLOR of any visible defects discovered and do not start work without their approval.**

## 1 - INTRODUCTION

These materials come in 1000mm sections (see sketches below) in order to cover two winder steps or two straight steps. Using the latest techniques, the edges of the steps may be joined and finished in two ways:

- **Clip system** (clipped finisher strips).
- **Cold sealing.**

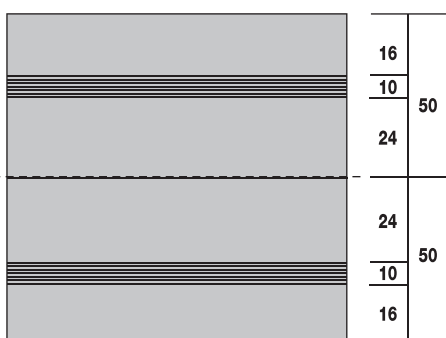

1000mm sections = 2 straight steps

100 cm

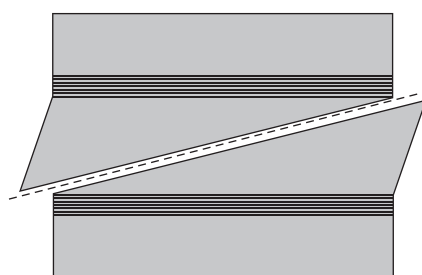

Or 2 winder steps

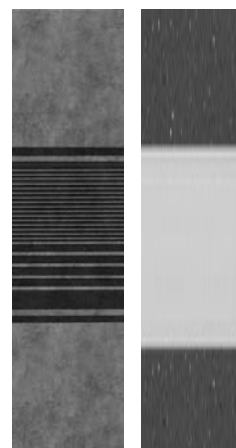

Contrast stair nosing  
Printed: TARASTEP STRADA  
Integral: TARASTEP COSTA RICA

See the colours available in the Buildings guide 2009/2010

## 2 - PREPARATION

### • 2.1 - SURFACES

The surfaces must be flat, sound, smooth, clean and dry.  
The nose radius of the step must be greater than 12mm.  
Skim the tread and riser of each step thoroughly with a stopper compound as laid down in the specifications. A thixotropic filler will not run and is recommended for the riser

#### 2.1.1 - Hooked nosing

Fill in the angle formed by the hooked nosing, as shown below:



#### 2.1.2 - Square nosing

Grind off or sand the nosing in several stages in order to leave a rounded edge of 12mm radius.



### • 2.2 - PREPARING AND CUTTING THE COVERING

- The step coverings must be cut to the length of the steps the night before, allowing 50mm excess length.
- For Tarastep materials, at least two hours before fitting, apply SM primer to the back of the step covering behind the nosing ribs.
  - This primer is not supplied with the material but may be obtained from Gerflor.
  - Follow the instructions on the container carefully (step coverings previously coated with primer on the back may be used at any time).
  - Quantity: Allow 1x tin of primer Taralay SM for each roll of Tarastep.

### • 2.3 - PRE-GLUING OF THE SURFACE

- Pre-glue the surfaces with a primer, using either a roller or a brush.

### • 2.4 - LANDING/NOSING JOINTS

- In order to keep landings a uniform colour, cut off the tread part of the step covering along the top rib.
- Lay the landing floor covering.
- Weld the nosing and landing coverings together.

### 3 - INSTALLING THE FIRST AND LAST STEP COVERINGS

The first and last step coverings must have a riser with a minimum depth of 100mm that contrasts visibly with the rest of the step covering.

**Step nosing's must meet the following requirements:**

- Visible contrast with the rest of the staircase
- Non-slip
- No excessive overhang above the riser.

#### Installation

Prepare the step coverings before installing them, i.e:

- Pre-cut the riser part to ensure at least 100mm of contrast will be visible against the rest of the step covering
- Cut out the same shape in the contrasting material, using the original off-cut as a pattern
- Hot melt weld the two pieces of covering before fitting the step covering, ensuring that it is flat.



Contrasting riser of  
100 – 160mm  
(at least 100mm)  
Hot welding  
Tread part



### 4 - INSTALLING THE STEP COVERINGS (BY CHOSEN FINISH TYPE)

#### 4.1 - CLIP SYSTEM FINISH

##### 4.1.1 - Fitting the base strip

- Using a 2-part contact adhesive, glue down the clip system base strip to the stair in the corner between the tread and the riser.

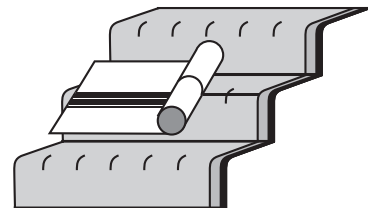
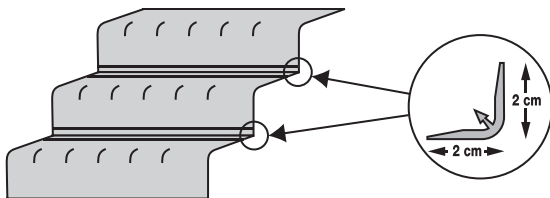

- Press down firmly and in the following order:

##### 4.1.2 - Installing the step coverings

- Start laying the covering from the foot of the stairs.
- Identify the rib in the step coverings that will be positioned at the start of the nosing radius and mark it with a chalked string line on the back of the covering (Line A below).

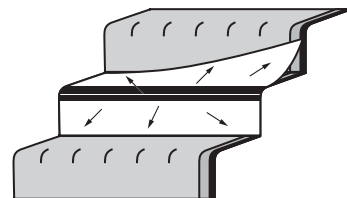
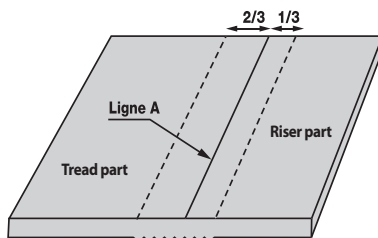

1. The ribs on the tread part, pressing longitudinally
2. The tread part, from the centre to the edges
3. The rounded part of the ribs, from the riser edge downwards
4. The riser itself, from the centre to the edges
5. Trim the step covering in the flat angles of the tread/riser against the side strips of the finishing clip system base and against the edges of the steps.

- Using a smooth spatula, apply contact adhesive to the back of the step covering and the step surface in a quantity of between 100 and 150g/m<sup>2</sup> per face.
- After observing the tack time, roll the step covering into position, first aligning the nosing and then rolling it out whilst checking that the nosing guideline remains properly aligned.

#### 4.1.3 - Fitting the moulding strip

- The moulding strip is then clipped to the base strip.

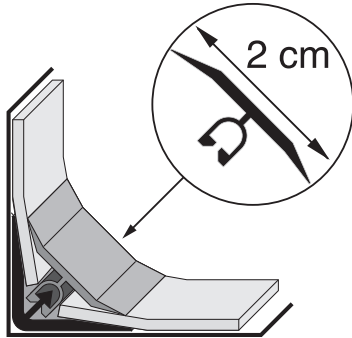

#### 4.2 - FINISHING: COLD SEAMING

##### 4.2.1 - Installing the step coverings

See paragraph 4.1.2

##### 4.2.2 - Sealing the joints

See diagram below.

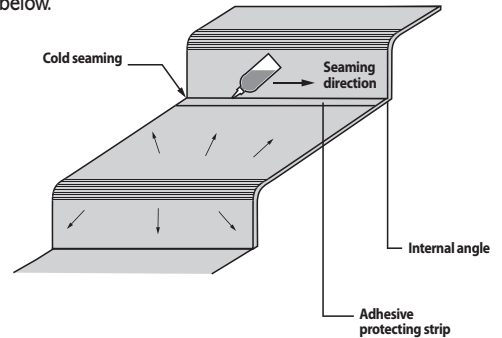

## 5 - INSTALLING WARNING PANELS

Both types of warning panels are to be fitted before installing the landing floor covering

- 400x1350mm for staircases
- 400x2000mm for corridors

At the top of the stairs, the floor covering must provide 500mm of warning before the top step, using visible and tactile contrasting material.

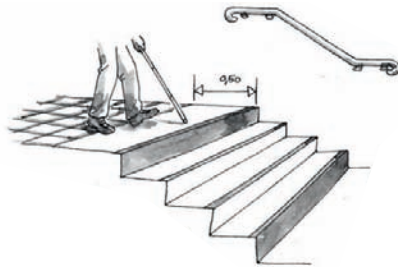

Use a gauge to cut out the landing floor covering around this panel.  
Cut a rib, hot melt weld and trim off the filler bead.

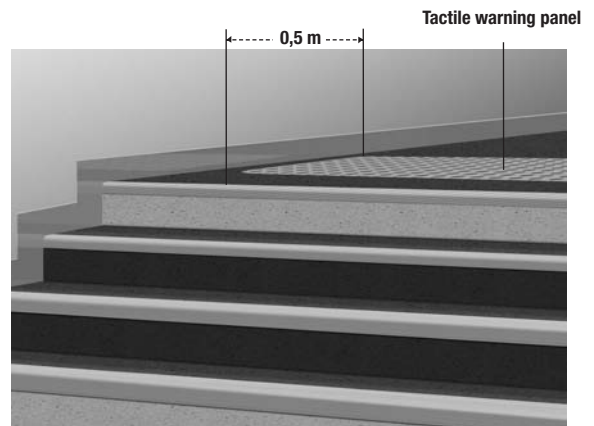

## 6 - JOINS AT LANDINGS

- The step covering's tread parts are to be cut off on landings at the base of the first rib on the nosing.
- The joint between the nosing and the landing floor covering is made by hot melt welding using a round filler bead, CR40

## 7 - OTHER TYPES OF STAIRCASE

- Spiral staircases round a central core: cover a central passage strip only.

- Metallic staircases with risers (rounded nosing):  
Degrease totally and strip the surface back to bare metal.

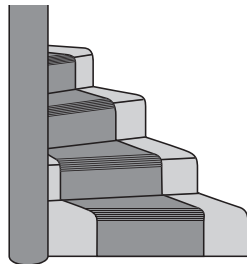

#### • SPECIAL CASE (Retirement homes)

Large tread area: weld with CR40 between the tread parts.  
Glue a 20mm support coving piece in the tread/riser corner.  
Fit the tread part (240mm) against the riser.

**One-piece step coverings cannot be used in the 3 following cases.**

- Concave or convex staircases
- Metallic nosed-step staircases with sharp nose angles or without risers.
- Open staircases without risers.

**Use a strip or tile-type floor covering with a separate nosing strip.**

