

# LAYING TECHNIQUES FOR LUXURY VINYL TILES OR PLANKS



Ambient temperature



Floor temperature

In accordance with the local standards

**Always check the material before starting work in order to avoid problems with visible defects.  
Please inform GERFLOR of any visible defects discovered and do not start work without their approval.**

## • 1 - MATERIAL INSPECTION

- Boxes are clearly marked with batch numbers and the product should be checked for match before installing.
- Inspect all materials carefully to verify that correct colors, lot number, patterns, quality and quantities have been shipped as ordered. Do not install, cut, or fit any material that has visible defects.
- A contractor that installs material that has visible defects or damage without prior consent of Gerflor deems the product acceptable for installation and therefore accepts full responsibility.

**NOTE:** Tiles have directional arrows and should be installed by alternating the arrows 90° forming a “checkerboard” pattern. Should the tiles be installed in the same direction, the seams will then be more visible, this is an observable fact inherent to the product.

Remove tiles or planks from the cartons 12 hours prior to installation.

Mix tiles or planks from different boxes when installing.

## • 2 - POSITIONING

The tiles or planks should be unpacked at least 12 hours before installation, and stored flat, on a full-length level surface in the site where they will be used.

### IMPORTANT

	LAYING DIRECTION
Tiles	90°c
Planks	Same direction

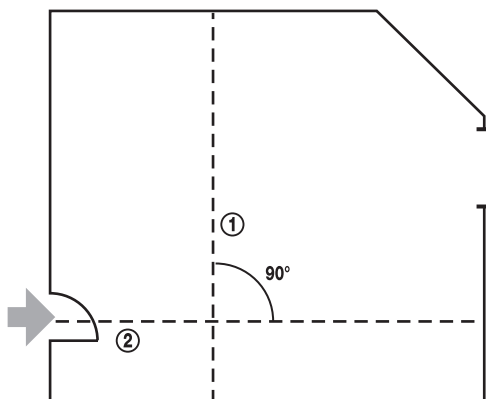

1. One guideline parallel with the main doorway
2. The other perpendicular to the main doorway, balancing the cut tiles

## • 3 - GLUING

Using acrylic emulsion adhesive.  
Spreading is with a fine toothed A2 type (TKB specification) Notched trowel giving an adhesive consumption rate of 300 / 350 g/m<sup>2</sup>.  
To achieve this distribution, blades have to be changed regularly.

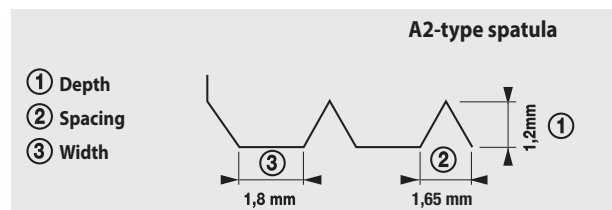

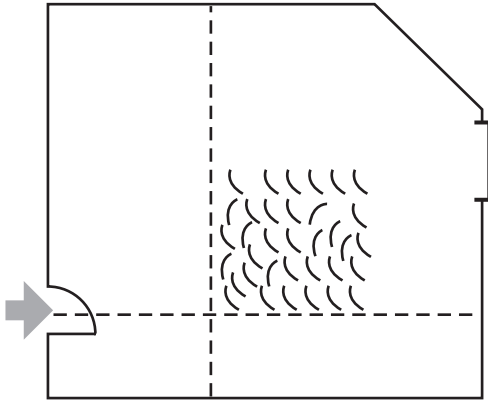

**NOTE!**

- Closely follow the adhesive manufacturer's instructions with particular regard to its waiting time.
- Consumption and spatula are recommended by Gerflor
- Room temperature and humidity, sub-floor absorption and adhesive consumption are important to have a perfect adhesion.
- Too short a waiting time and bubbling will occur.
- Too long a waiting time will result in poor transfer of the adhesive to the flooring (Schema).
- Ensure that just sufficient adhesive is applied to the sub-floor which corresponds to the number of tiles being installed so that the adhesive's waiting time is not exceeded.
- Apply adhesive to an area no larger than can be covered within the glue's working time.
- Remove any surplus glue spots whilst work is in progress.

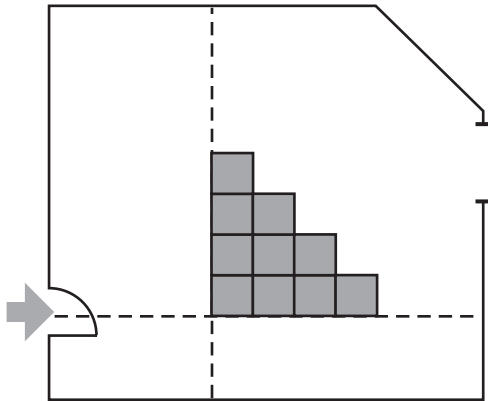

**GLUING THE FLOOR AND LAYING THE TILES**

**A - For square formats (STONE)**

- Lay down the tiles in a pyramid pattern along the guidelines on the floor
- Check the tile joints for evenness
- 90° lays (see TILE LAYING chapter).

**B - For plank formats (WOOD)**

**Installation theory**

- Divide the floor area into two parts with one guideline at right angles to the room's main doorway
- Position the first plank and then continue, following the guidelines (see sketch).

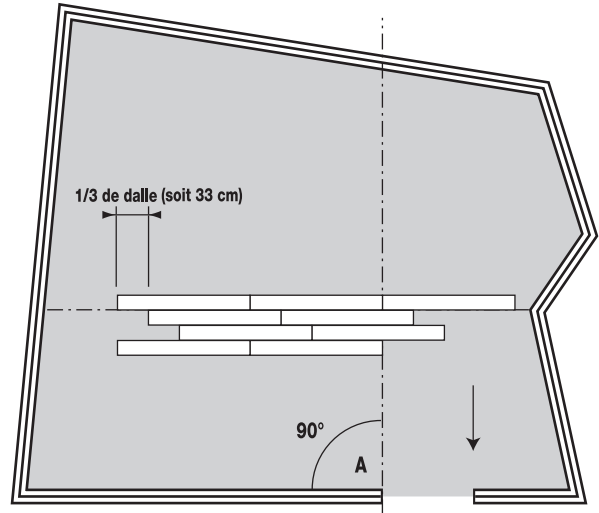

- The first plank in the next strip should be offset sideways by one third of its length to ensure that the joints repeat themselves every three strips. This is more aesthetically pleasing than repeating the joints every second strip.
- Alternatives include herringbone patterns, geometric layouts, etc
- Press down carefully to provide maximum adhesion.

**• 4 - ROLLING OUT**

This must be done in two stages:

- Manually, using a cork smoothing press
- Rolling out over the entire surface with a 50 Kg roller when installation is complete.

Stage 1: Pressing down manually

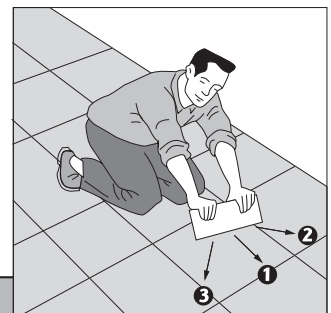

Stage 2: Using a roller

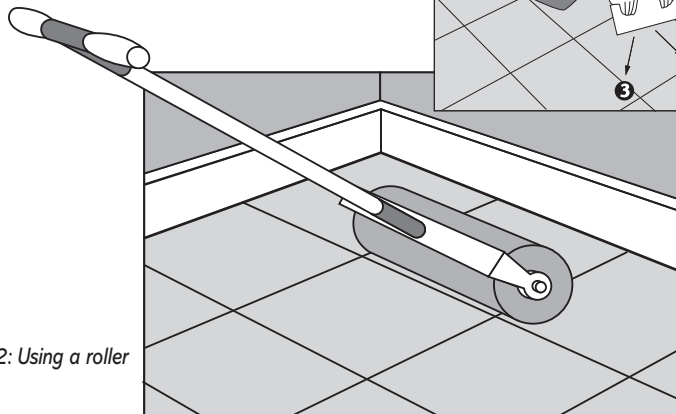

## • 5 - COMMISSIONING – TRAFFIC

After installation:

- For normal pedestrian traffic, allow 48 hours
- Before moving or installing furniture, allow 72 hours
- Do not use rubber furniture feet

For under-floor heating, do not turn on the heating for 7 days after installing the tiles.

## • 6 - DECORATIVE LAYOUTS WITH EDGINGS

- Position the decorative element in a balanced manner within the room
- For aesthetic and practical reasons, ensure that the decorative central part is sized in multiples of the tiles being installed.
- Mark out the guidelines at right angles

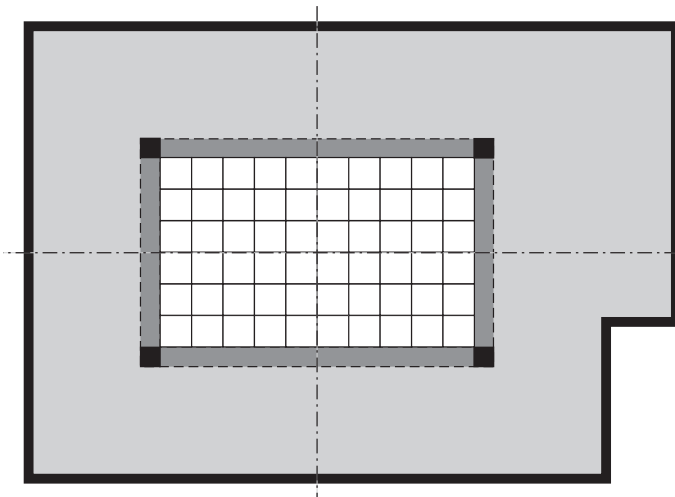
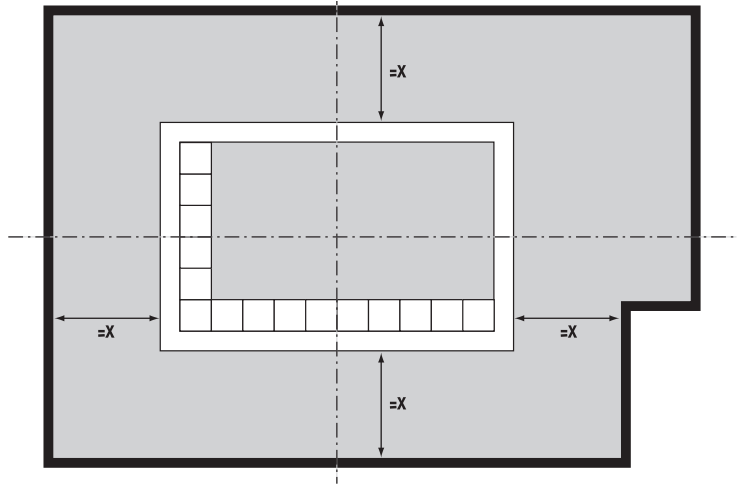

- Start by filling in the central part, following the marking-out guidelines.
- Position the corner pieces.

- Position the edging bands to match the patterns in the corners.
- Finish off by laying the surrounding floor covering.

