

Laying Techniques for Homogeneous and Multilayered Tiles Compact or Acoustic

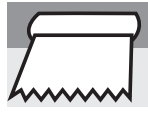

Ambient temperature



Floor temperature

According to the local Standard

**Always check the material before starting work in order to avoid problems with visible defects.
Please inform GERFLOR of any visible defects discovered and do not start work without their approval.**

• 1 - MATERIAL INSPECTION

- Boxes are clearly marked with batch numbers and the product should be checked for match before installing.
- Inspect all materials carefully to verify that correct colors, lot number, patterns, quality and quantities have been shipped as ordered. Do not install, cut, or fit any material that has visible defects.
- A contractor that installs material that has visible defects or damage without prior consent of Gerflor deems the product acceptable for installation and therefore accepts full responsibility.

Note: Tiles have directional arrows and / or pattern design should be installed by alternating the arrows 90° forming a "checkerboard" pattern. Should the tiles be installed in the same direction, the seams will then be more visible, this is an observable fact inherent to the product.

Remove tiles from the cartons 12 hours prior to installation.

Mix tiles from different boxes when installing

Welding joints: Hot welding is necessary for tiles larger than 500mm x 500mm.

• 2 - TILE LAYOUT

The tiles should be unpacked at least 12 hours before installation, and stored in the site where they will be used.

IMPORTANT

- Tracing the axes.

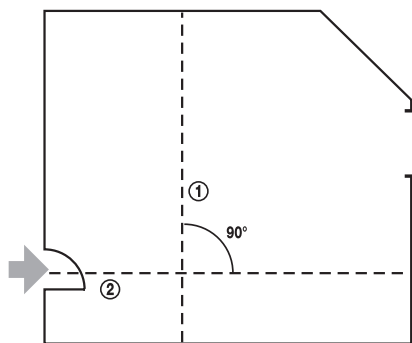

1. One guideline parallel with the main doorway
2. The other perpendicular to the main doorway, balancing the cut tiles

Direction for laying

90° lays is recommended

If for any reason, tiles are positioning in the same direction, the finish effects (matt/gloss) is eliminate BUT increases the visibility of the joints.

Welding joints: Hot welding is necessary for tiles larger than 500mm x 500mm.

• 3 - ACRYLIC ADHESIVE INSTALLATION

Using acrylic emulsion adhesive.

Spreading is with a fine toothed A2 type (TKB specification)

Notched trowel giving an adhesive consumption rate of 300 / 350 g/m².

To achieve this distribution, blades have to be changed regularly

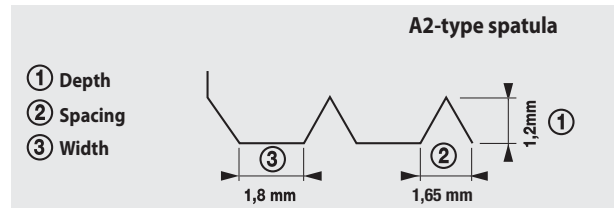

NOTE:

Closely follow the adhesive manufacturer's instructions with particular regard to its waiting time.

Consumption and spatula are recommended by Gerflor. Room temperature and humidity, sub-floor absorption and adhesive consumption are important to have a perfect adhesion.

- Too short a waiting time and bubbling will occur.
- Too long a waiting time will result in poor transfer of the adhesive to the flooring (Schema).
- Ensure that just sufficient adhesive is applied to the sub-floor which corresponds to the number of tiles being installed so that the adhesive's waiting time is not exceeded.

Apply adhesive to an area no larger than can be covered within the glue's working time

Remove any surplus glue spots whilst work is in progress

Apply adhesive to an area no larger than can be covered within the glue's working time

Remove any surplus glue spots whilst work is in progress.

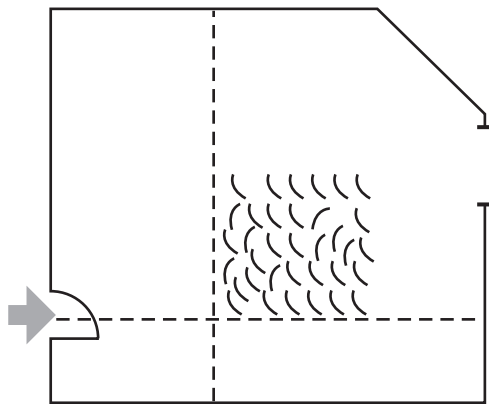

GLUING THE FLOOR AND LAYING THE TILES

- Lay down the tiles in a pyramid pattern against the guidelines on the floor
- Check the tile joints are but joint

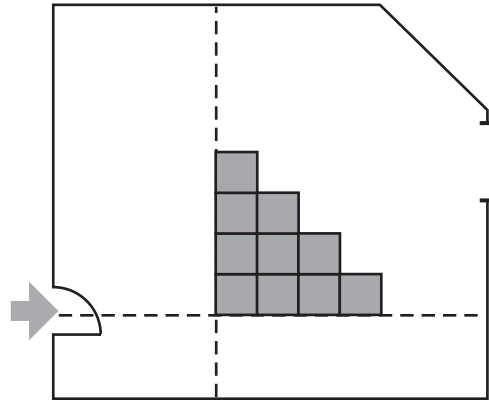

• 4 - ROLLING OUT

This must be done in two stages:

- Manually, using a cork smoothing press
- Rolling out over the entire surface with a 50 Kg roller when installation is complete

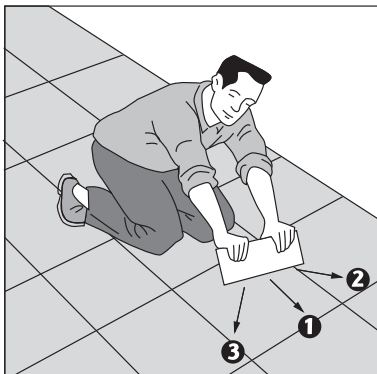

Stage 1: Pressing down manually

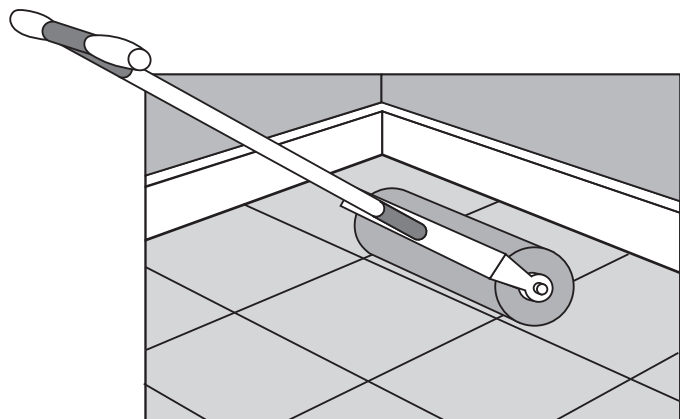

Stage 2: Using a roller

• 5 - HEAT WELDING

Tiles must be tight

Tiles must be hot welding as soon as they have a format more than 500 x 500 mm

For welding tiles, proceed as follows:

- Chamfer, weld and trim all in the same way eg: crossway before starting again to groove, weld and trim on the other side.eg: lengthway. This method avoid weld missing at the cross tiles.

See HEAT Welding Techniques

• 6 - PUTTING INTO SERVICE – TRAFFICKING

After installation:

- For normal pedestrian traffic, allow 48 hours
- Before moving or installing furniture, allow 72 hours
- Do not use rubber furniture feet

For under-floor heating, do not turn on the heating for 7 days after installing the tiles